

NAD 917

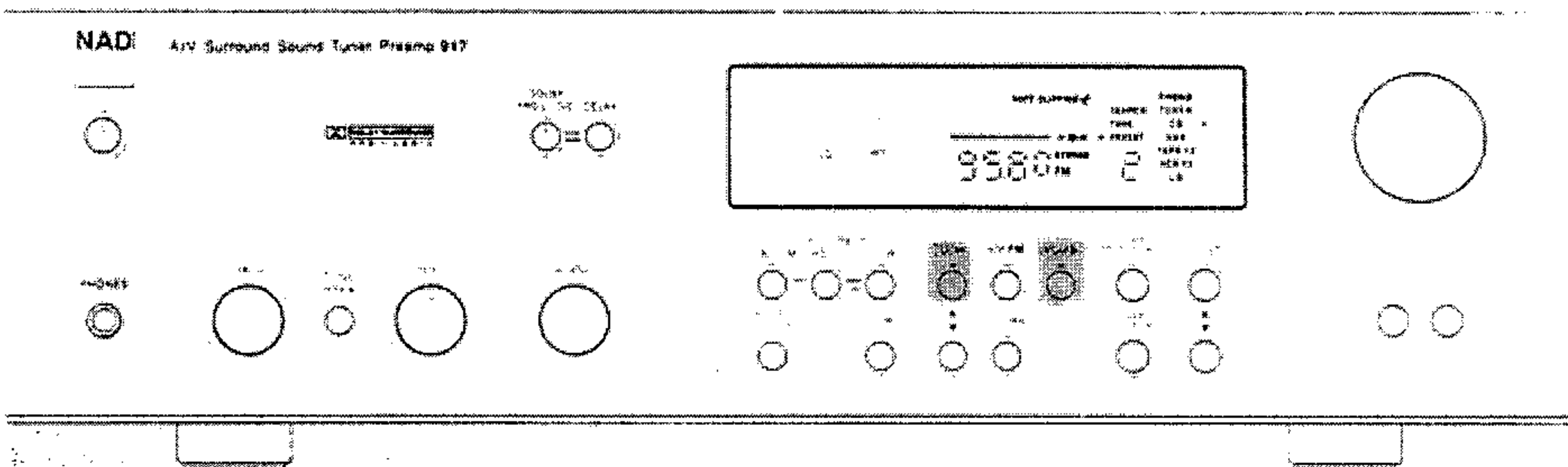

GB • **OWNER'S MANUAL**

WARNING: TO PREVENT FIRE OR ELECTRIC SHOCK, DO NOT EXPOSE THIS APPLIANCE TO RAIN OR MOISTURE

Note to CATV system installer: This reminder is provided to call the CATV installer's attention to Article 820-40 of the NEC, which provides guidelines for proper grounding and, in particular, specifies that the cable should be connected to the grounding system of the building, as close to the point of cable entry as practical.

THIS DIGITAL APPARATUS DOES NOT EXCEED THE CLASS B LIMITS FOR RADIO NOISE EMISSIONS FROM DIGITAL APPARATUS AS SET OUT IN THE RADIO INTERFERENCE REGULATIONS OF THE CANADIAN DEPARTMENT OF COMMUNICATIONS.

LE PRESENT APPAREIL NUMERIQUE N'EMET PAS DE BRUITS RADIOELECTRIQUES DEPASSANT LES LIMITES APPLICABLES AUX APPAREILS NUMERIQUES DE LA CLASSE B PRESCRITES DANS LE REGLEMENT SUR LE BROUILLAGE RADIO ELECTRIQUE EDICTE PAR LE MINISTERE DES COMMUNICATIONS DU CANADA.

CAUTION: TO PREVENT ELECTRIC SHOCK DO NOT USE THIS POLARISED PLUG WITH AN EXTENSION CORD RECEPTACLE OR OTHER OUTLET UNLESS THE BLADES CAN BE FULLY INSERTED TO PREVENT BLADE EXPOSURE.

ATTENTION: POUR PREVENIR LES CHOCS ELECTRIQUES NE PAS UTILISER CETTE FICHE POLARISEE AVEC UN PROLONGATEUR, UNE PRISE DE COURANT OU UNE AUTRE SORTIE DE COURANT, SAUF SI LES LAMES PEUVENT ETRE INSEREES A FOND SANS EN LAISSER AUCUNE PARTIE A DECOUVERT.

CAUTION
RISK OF ELECTRIC SHOCK DO NOT OPEN
CAUTION: TO REDUCE THE RISK OF ELECTRIC SHOCK, DO NOT REMOVE COVER (OR BACK). NO USER SERVICEABLE PARTS INSIDE. REFER SERVICING TO QUALIFIED SERVICE PERSONNEL.

ATTENTION:
RISQUE DE CHOC ELECTRIQUE NE PAS OUVRIE
AFIN DEVIETER UN CHOC ELECTRIQUE, ET LES CONSEQUENCES GRAVES QUI POURRAIENT EN RESULTER, TENTEZ PAS D'OUVRIR L'APPAREIL ET DE TOUCHER AUX COMPOSANTS INTERNES SANS LA PRESENCE D'UNE SERVICE PERSONNEL.

 The lightning flash with arrowhead, within an equilateral triangle is intended to alert the user of the presence of uninsulated "dangerous voltage" within the product's enclosure: that may be of sufficient magnitude to constitute a risk of electric shock to persons.

 The exclamation point within an equilateral triangle is intended to alert the user of the presence of important operating and maintenance (servicing) instructions in the literature accompanying the appliance

REAR PANEL CONNECTIONS

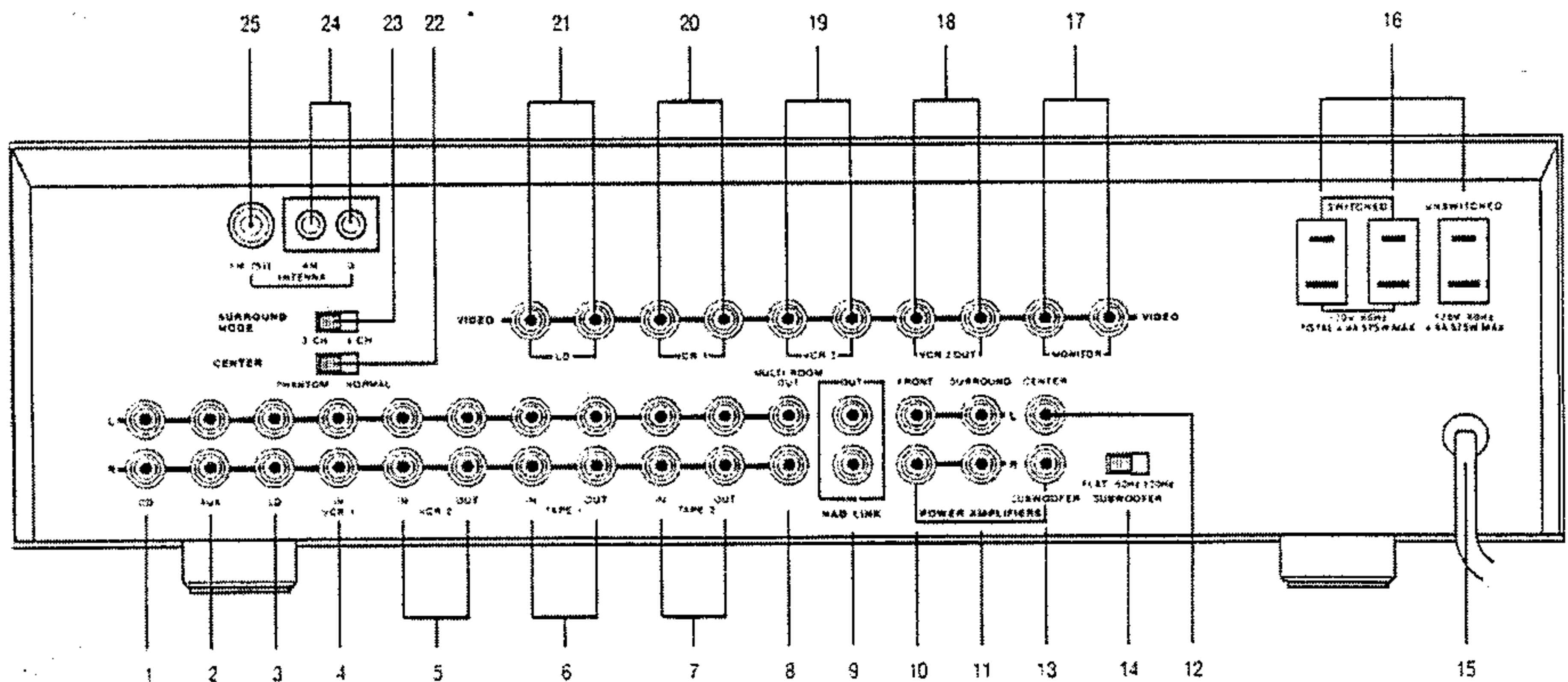

FRONT PANEL CONTROLS

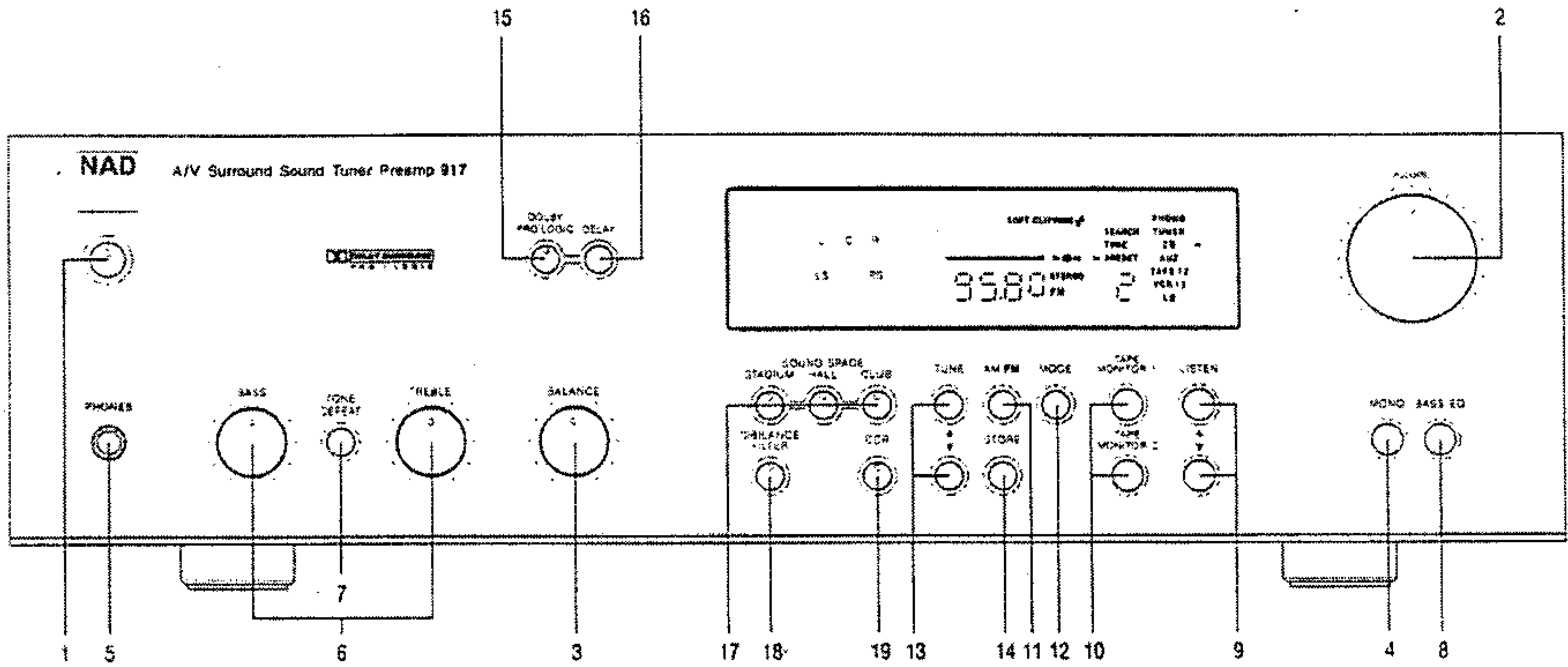

REMOTE CONTROL

Figure 1.

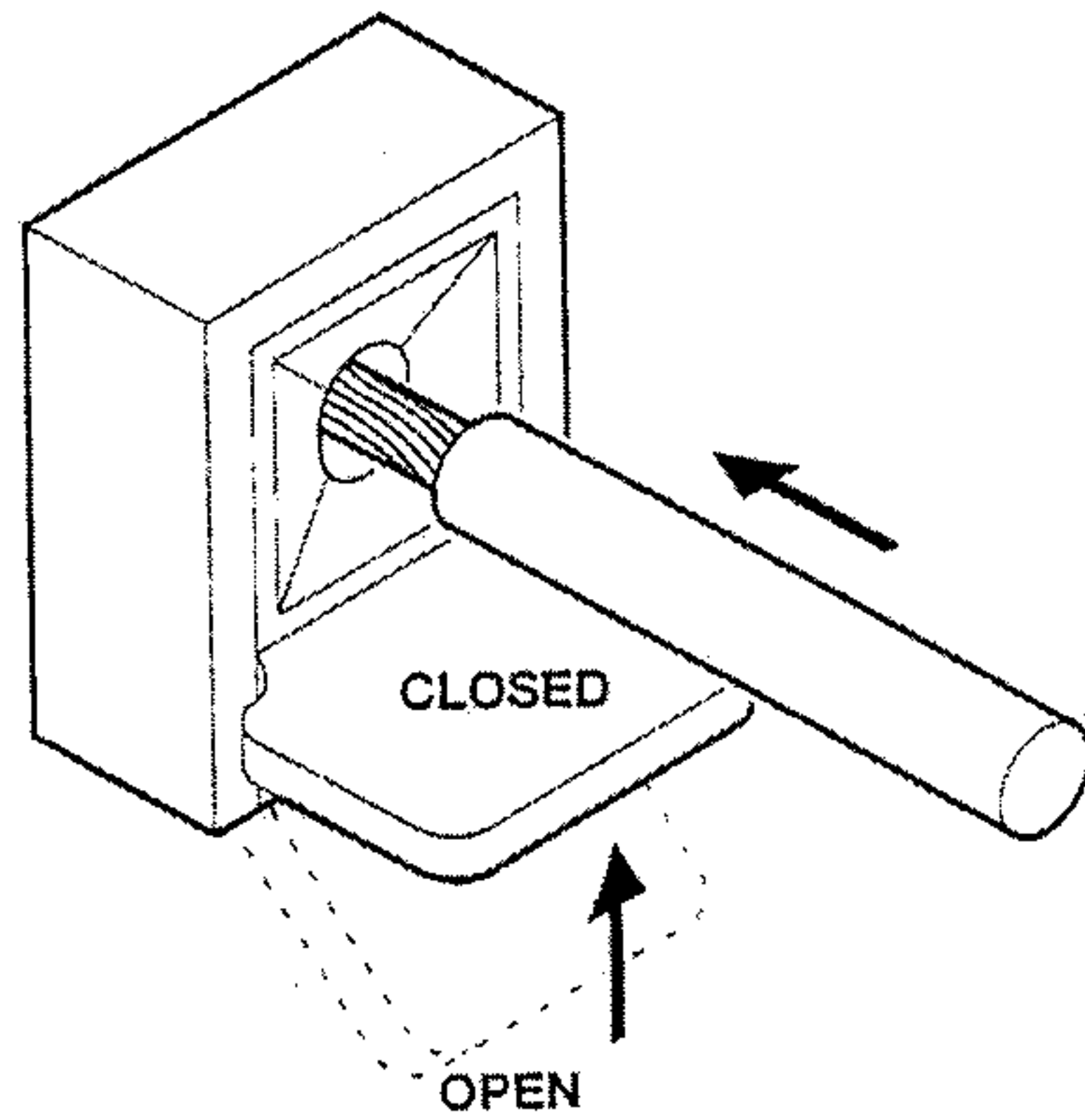
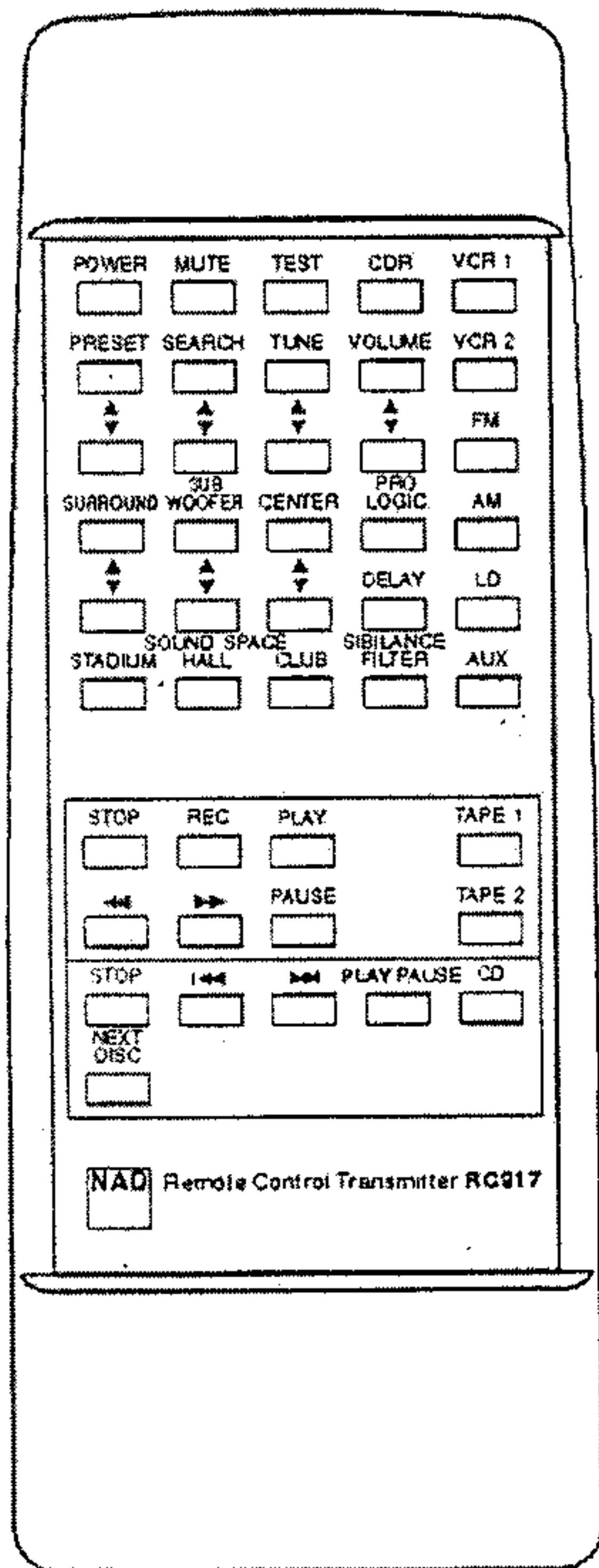

Figure 2.

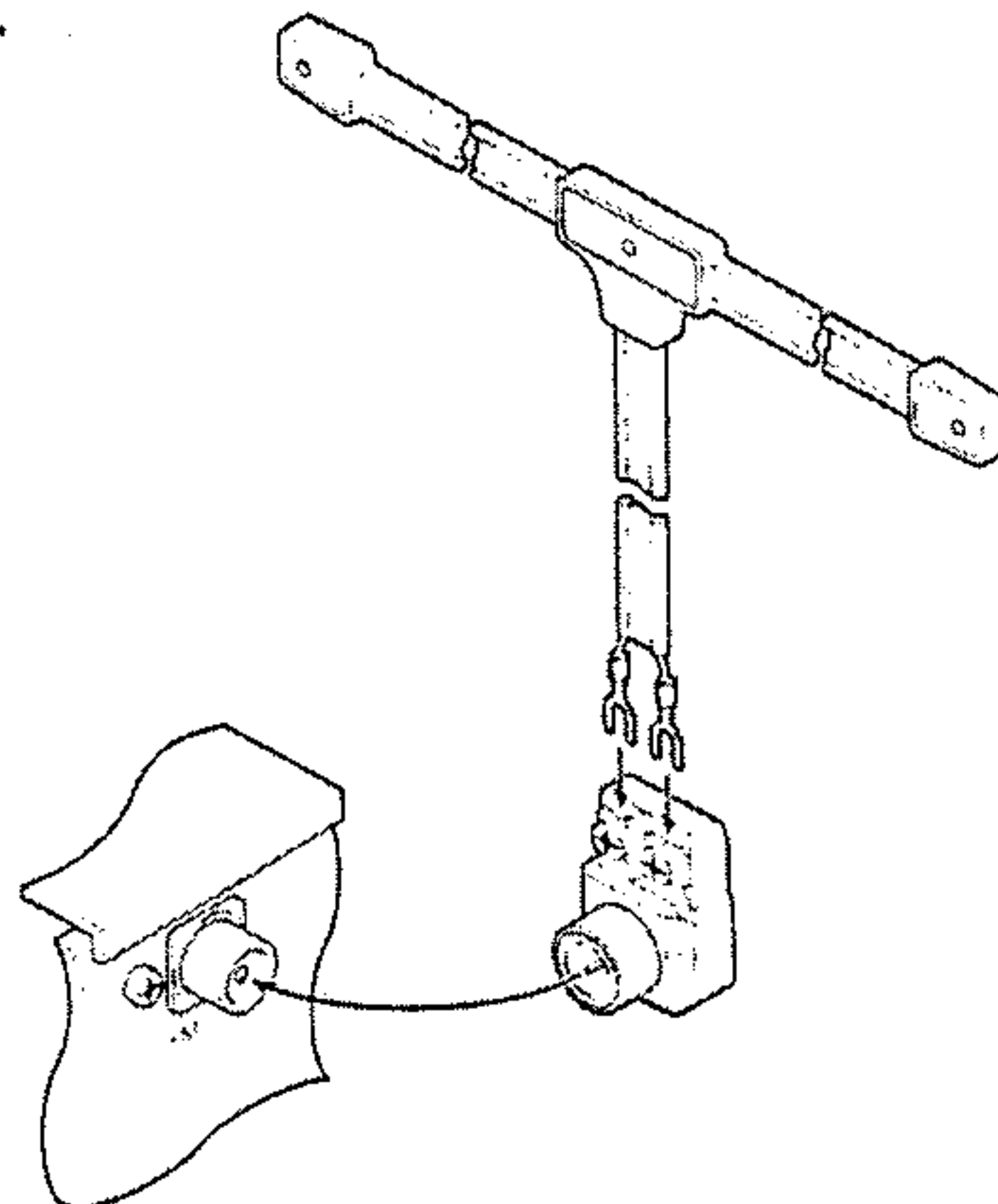

Figure 3. Simple A/V System

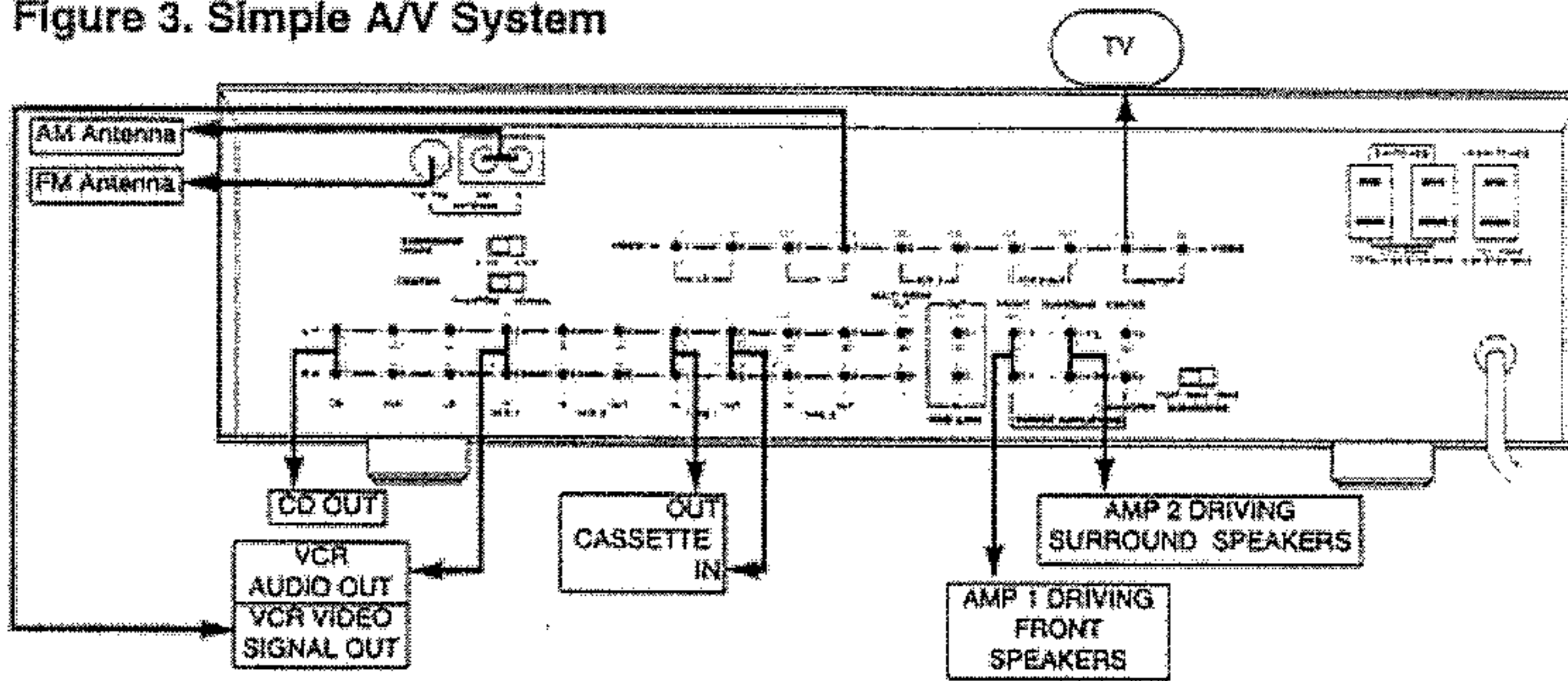

Figure 4. Sophisticated A/V System

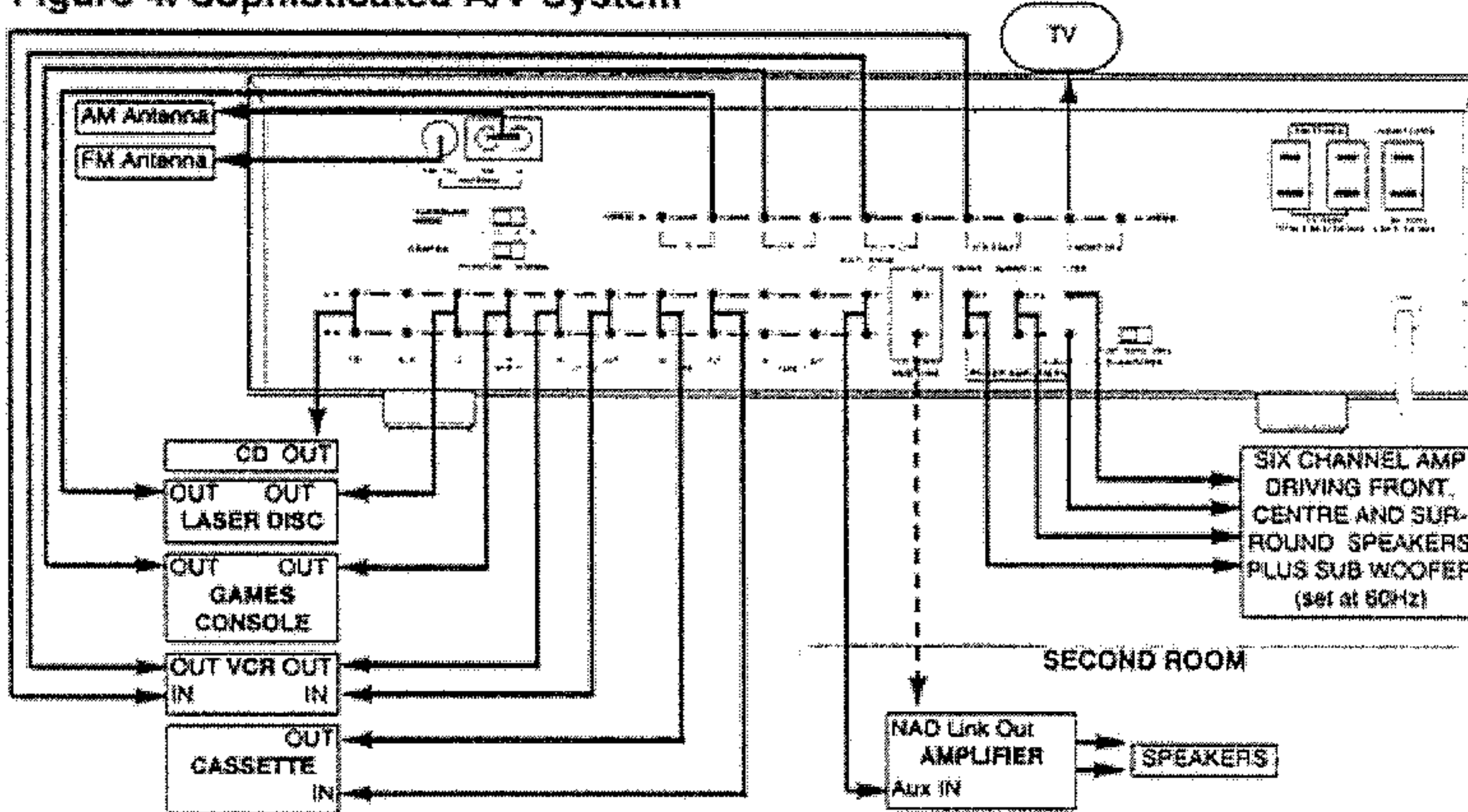
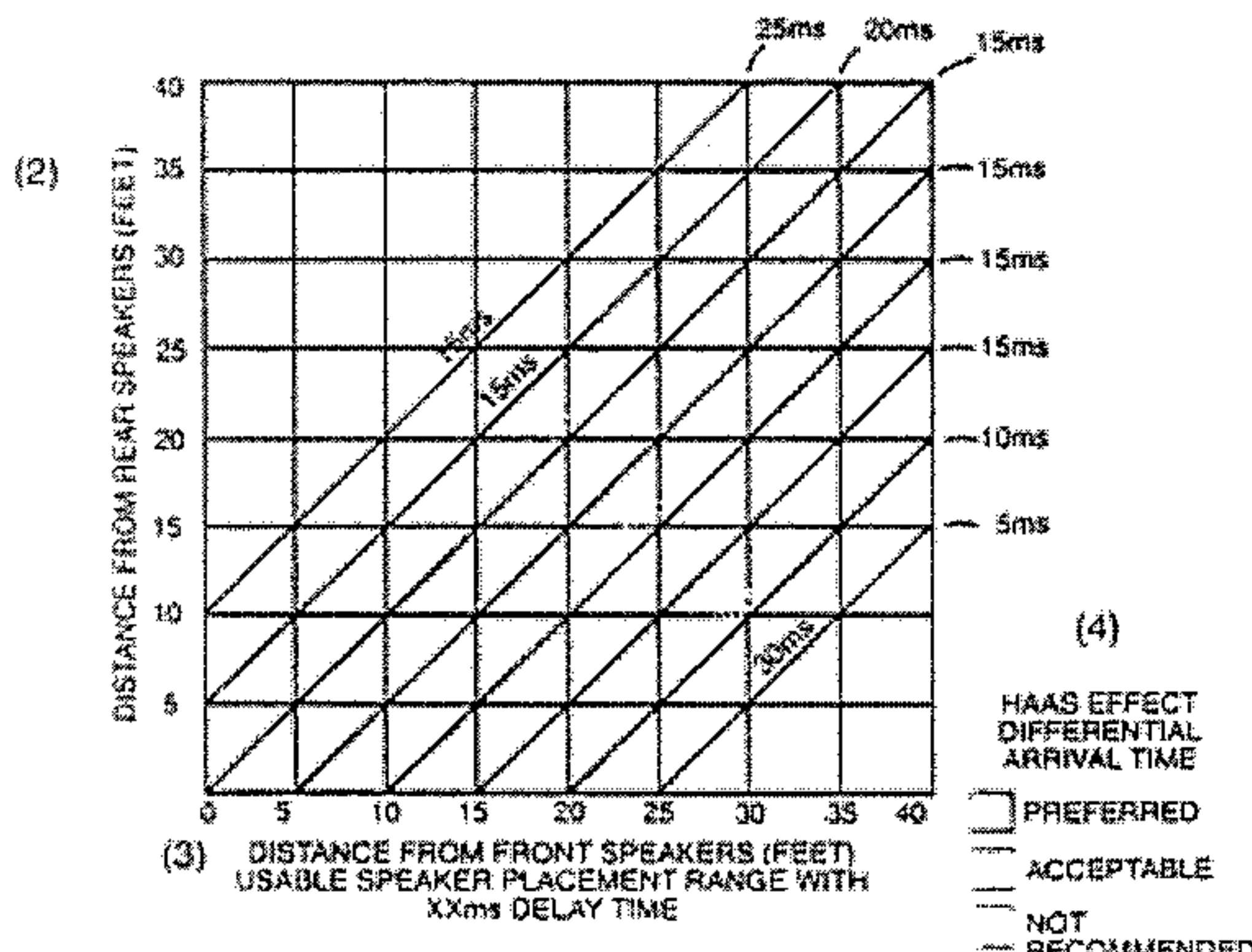

Figure 5. DOLBY DELAY (1)



(1) RETARD DOLBY - DOLBY SCHALLVERZUG - RETARDO COLBY - RITARDO DOLBY - DOLBY TIDSFÖRDRÖJNING.
 (2) DISTANCE DES HAUTS-PARLEURS ARRIERE (PIEDS/METRES) - ABSTAND VON DEM HINTERGRUND-LAUTSPRECHERN - DISTANCIA DESDE ALTAVOCES TRASEROS (PIES) - DISTANZA DAGLI ALTOPARLANTI POSTERIORI (PIEDI) - AVSTÄND TILL SURROUNDHÖGTALRNA MÄTT I FOT (EN FOT = 30 cm).
 (3) DISTANCE DES HAUT-PARLEURS AVANT (PIEDS/METRES) PLAGE UTILISABLE POUR LA DISPOSITION DE HAUT-PARLEURS AVEC UN TEMPS DE RETARD DE XXms. - ABSTAND VON DEN VORDERGRUND-LAUTSPRECHERN (FUß) MÖGLICHE LAUTSPRECHERANORDNUNG MIT SCHALLVERZUG VON XXms. - DISTANCIA DESDE ALTAVOCES DELANTEROS (PIES) GAMA DE COLOCACION DE ALTAVOCES UTILIZABLE CON TIEMPO DE RETARDO DE XXms. - DISTANZA DAGLI ALTOPARLANTI ANTERIORI (PIEDI) CAMPO EFFETTIVO DI PIAZZAMENTO ALTOPARLANTI CON COEFFICIENTE DI RETARDO XXms. - AVSTÄND TILL FRONTHÖGTALRNA MÄTT I FOT. ANVÄNDBAR HÖGTALARPLACERING INOM XXms TIDSFÖRDRÖJNING.
 (4) TEMPS D'ARRIVÉE DIFFÉRENTIEL AVEC EFFET DE HAAS/PREFERABLE/ACCEPTABLE/A EVITER - HAAS-EFFEKT-SCHALLVERZUG/OPTIMAL/AUSREICHEND/UNGEEIGNET - EFFECTO HAAS TIEMPO DIFERECIAL DE LEGADA/PREFERIDO/ACEPTABLEE/NO RECOMENDADO - TEMPO DI ARRIVO AIFFERENZIALE EFFETTO HAAS/PREFERITO/ACCETTABILE/NON RACCOMANDATO - ATT FÖREDRA/ACCEPTABELT/INTE ATT REKOMMENDERA

NAD 917 A/V PREAMP TUNER**GB****NOTES ON INSTALLATION.**

Your 917 should be placed on a firm, level surface. Avoid placing the unit in direct sunlight, near sources of heat and damp or in poorly ventilated positions.

Switch the unit to standby before making any connections. The phono connectors on your 917 are colour coded for convenience. Red and white are Right and Left audio, yellow is composite (line) video and orange for NAD-Link.

The 917 comes with phono leads for basic connections. Where additional leads are required, use high quality leads and connectors for optimum performance and reliability of connection. Audio phono leads will function correctly for video signals, although it is recommended to use dedicated video leads where possible. Ensure that leads and connectors are not damaged in any way and all connectors are firmly pushed home.

If the unit is not going to be used for some time, disconnect the plug from the AC socket.

Should water get into your 917, shut off the power to the unit and remove the plug from the AC socket. Have the unit inspected by a qualified service technician before attempting to use it again.

Do not remove the cover, there are no user-serviceable parts inside.

Use a dry soft cloth to clean the unit. If necessary, lightly dampened the cloth with soapy water. Do not use solutions containing benzol or other volatile agents.

WARNING TO UK USERS. If this apparatus is fitted with a two-pin Europlug, do not attempt to insert the plug into a UK mains socket. Instead, cut the plug from the mains lead and attach a fused UK three-pin plug using the following safety advice on wiring.

IMPORTANT. The wires in this mains lead are coloured **BLUE** and **BROWN**;

BLUE: NEUTRAL BROWN: LIVE

The colours of these mains lead wires may not correspond with the coloured markings identifying the terminals in your plug. In this case the **BROWN** wire must be connected to the terminal which is marked **L(ive)** or coloured **RED**. The **BLUE** wire must be connected to the terminal marked **N(eutral)** or coloured **BLACK**. No connection should be made to the terminal marked **E** or coloured green or green and yellow

REAR PANEL CONNECTIONS**1. CD INPUT**

Input for CD player (analogue audio signal) or other line-level signal source. Use a twin phono-to-phono lead to connect the CD player left and right 'Audio Outputs' to this input.

2. AUX INPUT

Input for additional line level input signals such as another CD player. Connect the auxiliary unit's left and right 'Audio Outputs' to this input.

3. LD INPUT

Laser Disc input for the audio signal from a Laser Disc or other video playback unit, such as Video-CD, computer systems or games consoles. Using twin phono-to-phono leads, connect the left and right 'Audio Out' of the Laser Disc to the inputs on the NAD 917 marked 'LD'. These audio inputs are used in conjunction with the composite (line) or S-VHS video inputs marked VIDEO LD. See 16 for connecting the Laser disc signal.

4. VCR 1.

Inputs for audio playback from a VCR or other video device such as a satellite or cable receiver. Using twin phono-to-phono leads, connect to the left and right 'Audio Out' of the VCR/satellite receiver to the inputs on the NAD 917 marked 'VCR 1'. These audio inputs are used in conjunction with the composite (line) or S-VHS video inputs marked VIDEO LD. VCR 1 is for playback only, to connect a VCR for recording and playback through the NAD 917, use VCR 2. See 16 for connecting the VCR/satellite receiver signal.

5. VCR 2.

Connections for audio recording playback to a VCR or other video recorder. Using twin phono-to-phono leads, connect the left and right 'Audio Out' of the VCR to the VCR 2 IN connectors on the NAD 917 for playback. Connect the left and right 'Audio In' of the VCR to the VCR 2 OUT connectors on the NAD 917 for recording. These audio inputs are used in conjunction with the composite (line) or S-VHS video inputs marked VIDEO VCR 2 and the video outputs marked VCR 2 OUT. See 16 for connecting the VCR/satellite receiver signal.

6. TAPE 1

Connections for analogue recording and playback to an audio tape recorder of any type, such as a cassette, reel-to-reel, DAT, MD or DCC. Using twin phono-to-phono leads, connect to the left and right 'Audio Output' of the tape machine to the TAPE 1 IN connectors for playback. Connect the left and right 'Audio Input' of the tape machine to the TAPE 1 OUT connectors for recording. The choice of signal being sent to the tape machine is selected from the front panel.

7. TAPE 2

Connections for analogue recording and playback to a second audio tape recorder of any type. Using twin phono-to-phono leads, connect to the left and right 'Audio Output' of the tape machine to the TAPE 2 IN connectors for playback. Connect the left and right 'Audio Input' of the tape machine to the TAPE 2 OUT connectors for recording. The choice of signal being sent to the tape machine is selected from the front panel.

8. MULTI ROOM OUT

This connector provides a fixed line level output that corresponds to the current front panel INPUT selection. This allows the 917 to supply a signal to sound systems in other rooms. Connect the MULTI ROOM



OUT to a spare line level input (eg 'Aux In') on the second system. Because of the long leads often required for Multi Room installations, for optimum performance use high quality cables for the connections.

9. NAD-LINK IN OUT

The NAD-Link connector is used to pass commands from the remote control to and from other units fitted with NAD-Link connectors. This allows centralised control of a complete system or gives system control from more than one room. To function with other units, connect the 917's NAD-Link OUT to NAD-Link IN on the other unit. NAD-Link connectors can be daisy-chained, IN to OUT, so that a whole system can be controlled from the remote control facilities of one unit.

A single NAD-Link connection from a hi-fi system in a second room will allow remote control of Multi Room systems.

10, 11, 12, 13. POWER AMPLIFIERS

The 917 does not contain power amplifier sections, and needs to be connected to external power amplifiers. These connectors supply the signals for the Front Left, Center and Right channel power amplifiers, the Left and Right Surround channels and the Sub Woofer channel.

The 917 can function as a normal 2-channel stereo receiver, three channel Front-only Dolby Pro Logic system or a full surround Dolby Pro Logic system depending on the number of amplifier channels and speakers. A Sub Woofer can be added to any of these modes.

A combination of single channel or stereo power amplifiers can be used with the 917. Whilst amplifiers of different powers and types can be used, it is recommended that Front Left and Right channels and preferably, the Front Center channels, all use identical power amplifier sections such as the NAD 214 or NAD 216. Alternatively, a dedicated six channel Home Theater power amplifier such as the NAD 916 can be used. The POWER AMPLIFIER sockets should be connected to the 'Line Inputs' of the power amplifier. (See the power amplifier's instruction information for more information regarding connection.)

The relative levels between the channels and the overall volume level is set by controls on the 917. If the power amplifier has its own volume controls, set these to a middle level (approx 12 o'clock position) and these should then remain unaltered during normal operation.

Connect the Front Left and Right amplifier channels to FRONT (10). Connect the Front Center amplifier channels to CENTER (12). Connect the Surround Left and Right amplifier channels to SURROUND (11). These are used in conjunction with the two DOLBY selectors on the rear panel.

Connect the Sub Woofer amplifier channel to SUBWOOFER (15). This is used in conjunction with the SUBWOOFER selector on the rear panel.

14 SUBWOOFER SELECTOR

The 917's dedicated Sub Woofer output combines the low frequencies from the Left and Right channels

and is designed to work with a Sub Woofer driven by its own power amplifier channel. This can either be a separate Sub-bass speaker and amplifier, or an 'active' Sub Woofer which combines amplifier and speaker into one unit. The SUBWOOFER selector switch sets the upper frequency limit to the bass signal being delivered to the SUBWOOFER connector. It should be set according to the type of Sub Woofer being used. This is especially useful when a separate Sub-bass speaker and amplifier are being used, which does not have low frequency filters.

Small Sub-bass speakers are typically are designed to reinforce the bass performance rather than go down to extreme low frequencies. For these types of Sub Woofer systems, set the selector to 120Hz. Larger Sub-bass speakers are designed only to work at very low frequencies, between 20Hz and 60Hz. For these types of Sub Woofer systems set the selector to 60Hz.

Most active Sub Woofers have their own built-in filtering circuits. In these cases, select the FLAT position, which delivers an un-filtered signal to the Sub Woofer. This avoids using two filtering circuits in the Sub Woofer chain. See your Active Sub Woofer or Sub-bass speaker's instruction manual for further information about performance and filtering requirements.

15. AC POWER CORD

Plug the AC power cord into a live AC socket. The 'Standby' indicator on the power switch is illuminated when power is being supplied to the 917. For U.S. only versions: In standby, the Switched AC convenience outlets will be off and the Unswitched AC convenience outlet will continue to supply power.

16. AC OUTLETS (US version only)

The AC power of cords other units in the audio system can be connected directly to the convenience AC outlets. The single UNSWITCHED outlet will supply power continually as long as the 917 is connected to a live AC socket. When the 917 is switched off, units connected to the two SWITCHED outlets will be also switched off.

The UNSWITCHED Outlets should be used with units with a COMBINED power consumption of no more than 525 Watts (4.8A). The SWITCHED outlet should be used with a unit that draws no more than 525 watts (4.8A)

17. MONITOR VIDEO OUTPUT

Composite (line) and S-VHS outputs for viewing video sources connected to LD, VCR1 or VCR2. Using a phono lead, connect the 'Video Line In' on the TV or monitor to the MONITOR VIDEO OUTPUT. Alternatively, if the TV or monitor has an S-VHS input, use a S-VHS lead to connect its S-VHS input to MONITOR VIDEO OUTPUT. This output can also be used as an additional recording output if required. Video monitoring must then be done via the output of the video recorder.

18. VCR2 VIDEO OUTPUT

Composite (line) and S-VHS outputs for recording video sources connected to LD or VCR1. Using a



phono lead, connect the 'Video In' of the VCR to VCR2 VIDEO OUTPUT for recording. Alternatively, if the video unit has an S-VHS output, use a S-VHS lead to connect the 'Video In' of the VCR to the VCR2 VIDEO OUTPUT for recording.

19, 20, 21. VIDEO INPUTS

Composite (line) and S-VHS inputs for video sources. Using a phono lead, connect the 'Video Out' of the LD, VCR or satellite unit for playback. Alternatively, if the video unit has an S-VHS output, use a S-VHS lead to connect the 'Video Out' of the LD, VCR or satellite unit for playback. Selecting LD, VCR1 or VCR2 on the front panel of the AV-917 will route the relevant video signal to the MONITOR and VCR2 OUT connectors.

IMPORTANT: S-VHS and standard composite video (the phono Video connectors) cannot be mixed within the 917. Either *all* video input and output connections should use the phono video connectors or they should *all* use S-VHS connectors.

22. DOLBY PHANTOM/NORMAL SELECTOR

The operation of the 917 can be preset to work with a two Front channel speakers (Left and Right) or three Front channel speakers (Left, Center, Right).

Set selector to PHANTOM for a system using two Front speakers. The Center channel information is shared between the Left and Right channels, creating a 'phantom' center image.

Set selector to NORMAL for a system using three Front speakers. In this mode, Dolby Pro Logic circuit delivers three discrete channels of sound to the front speakers. For improved performance and additional clarity, especially on dialogue, it is recommended to use the 917 with a Center channel speaker.

The NORMAL mode has a 100Hz filter on the Center channel to drive smaller speakers.

23. DOLBY 3CH/4CH SELECTOR

The operation of the 917 can be preset to work with a Front channel-only Dolby Pro Logic set-up or a full surround Dolby Pro Logic set-up.

Set selector to 3CH for systems with Front Left, Center and Right speakers but no Surround speakers. In this mode, the surround information produced by the Dolby Pro Logic circuit is mixed with the Front Left and Right signals and the surround POWER AMPLIFIER SURROUND outputs remain unconnected.

Set selector to 4CH for systems with Front Left, Center, Right and Surround speakers. In this mode, the surround information produced by the Dolby Pro Logic circuit is fed directly to the Surround channels.

24. AM ANTENNA

An AM wire antenna is supplied with the 917 and is required for AM reception. To connect the AM antenna, first press the key on the Antenna terminals downwards. Insert the bare antenna wire into the terminal hole and push the connector key upwards again to secure the connection.

Test various positions for the antenna but always ensure the wire is placed vertically for best reception. Placing the antenna close to large metal items such

as metal shelves or radiators may interfere with reception. (see Figure 1)

The effectiveness of a wire antenna may be improved by connecting a second wire from the ground (G) terminal to a true earth-ground, i.e. a copper-plated rod driven several feet into the earth. A substitute electrical ground, such as a cold water pipe, may also prove effective.

25. FM ANTENNA

A ribbon wire FM antenna is included and should be connected to the FM connector at the rear of the unit using the 'balun' adapter supplied. (see Figure 2) The ribbon aerial should be mounted on a vertical surface and placed so that it forms a 'T'

Experiment with placement of the antenna to find the position that gives the best signal strength and lowest background noise. The Tuner signal strength meter in the display panel will help to indicate the better antenna positions.

An inadequate FM signal normally results in high levels of hiss, especially in stereo, and interference from external electrical sources. In areas of poor FM reception, the tuner section's performance can be improved by using an externally mounted FM antenna. A qualified aerial installer will be able to advise and fit a recommended aerial for your reception conditions.

FRONT PANEL CONTROLS.

POWER, VOLUME, BALANCE, MONO AND HEADPHONE FUNCTIONS.

1. POWER

The green standby indicator shows that power is being supplied to the 917, but the system is currently off. Pressing the power switch turns the unit on and supplies power to the switched AC outlets. The display panel will indicate 917's current settings. When power is on, the standby indicator will light when a signal is being received from the Remote Control.

Pressing the power switch again will turn the 917 to Standby. When switched to standby, the unit stores the current input and mode settings in a non-volatile memory. The 917 returns to these modes when it is next switched on. The 917 also uses the non-volatile memory to store pre-set information, both for the tuner and for the Dolby Pro Logic set-up, so that these are not lost when the unit is switched to standby or disconnected from the AC supply.

CAUTION: When in standby, power is still supplied to the 917 and the unswitched AC outputs. Disconnect the 917 from the AC outlet when it is not being used for long periods of time.

2. VOLUME

The VOLUME control adjusts the overall loudness of the signals being fed to the power amplifiers. The VOLUME control does not affect recordings made using the tape or VCR line outputs or the level of the MULTI ROOM output.



3. BALANCE

The BALANCE control adjusts the relative levels of the Left and Right speakers. The 12 o'clock position provides equal level to the Left and Right channels. A detent indicates this position.

Rotating the control clockwise moves the balance towards the right. Rotating the control anti-clockwise moves the balance to the left. The BALANCE control does not affect recordings made using the tape or VCR line outputs.

4. MONO

The MONO button switches the 917 to MONO operation. Depress the MONO button in for Mono operation and press the MONO button again to return to Stereo operation. MONO applies to any signal passing through the 917. It should normally be used only with a single channel mono input or to switch the Tuner operation to Mono.

5. HEADPHONE SOCKET

A 1/4" stereo jack socket is supplied for headphone listening. The socket has its own amplifier which will drive conventional headphones of any impedance. It takes its signal from the Front Left and Right channels and works on all inputs, although any surround mode will be heard as two channel stereo. The volume and tone and balance controls are operative for headphone listening. To use headphones with other types of connector use a suitable adapter. Warning: Listening at high levels can damage your hearing.

TONE & DYNAMIC CONTROLS.

6. BASS & TREBLE CONTROLS

The 917 is fitted with BASS and TREBLE tone controls to adjust the overall tonality of your system.

The 12 o'clock position is 'flat' with no boost or cut and a detent indicates this position. Rotate the control clockwise to increase the amount of Bass or Treble. Rotate the control anti-clockwise to decrease the amount of Bass or Treble. These controls affect the Left and Right speakers only. In Pro Logic or Sound Space modes, the Center and Surround speakers maintain a 'flat' response, regardless of the tone control settings. The Tone controls do not affect recordings made using the tape or VCR line outputs.

7. TONE DEFEAT

The TONE DEFEAT switch by-passes the tone control section of the 917. If the Tone Controls are not normally used and left in the 12 o'clock position, then it is advisable to switch out the Tone Control section altogether by using this switch. In the 'out' position, the Tone Control circuits are active, pushing the TONE DEFEAT switch in bypasses the Tone Control section.

8. BASS EQ

The BASS EQ button is a fixed frequency Tone Control that increases the level of the extreme bass frequencies. This can be used to increase the bass output of a system, or to compensate for the lack of apparent bass when listening at low levels. Press the BASS EQ button to increase the extreme bass. To return to a flat frequency response, press the BASS

EQ button again so that it is in the 'out' position. This control affects the Left and Right speakers only. In Dolby Pro Logic or Sound Space modes, the Center and Surround speakers maintain a flat response, regardless of the BASS EQ settings. The BASS EQ control does not affect recordings made using the tape or VCR line outputs.

LISTEN (INPUT) & MONITOR SELECTORS.

9. LISTEN

The LISTEN ▲ ▼ buttons control which input source is being passed through the 917 and onto the power amplifiers and speakers. The input being currently heard is indicated by a ◀ on the Display Panel. Pressing ▼ moves down the list of input options and pressing ▲ moves up the list. When on TAPE 1 or VCR 1, pressing ▼ once again will switch to TAPE 2 or VCR 2. The signal is also routed to the TAPE OUT and VCR OUT connectors for recording. (Tuner can also be selected by pressing either the AM FM or ▲ ▼)

10. MONITOR 1 & 2

To monitor recordings being made on TAPE machines connected to TAPE 1 or TAPE 2 press MONITOR 1 or MONITOR 2 buttons. The button indicator illuminates when the monitor mode has been selected.

TUNER.

11. AM FM SELECTOR

The AM FM button switches the tuner between AM and FM reception. The display panel shows the frequency of the tuned station and which band is selected. Pressing AM FM will automatically select Tuner as the 917's input

12. TUNING MODE

The MODE button switches between the 917's three tuning modes: SEARCH, TUNE and PRESET. It is used in conjunction with the ▲ ▼ (13) and STORE (14) buttons to Tune, Store and Recall up to 19 FM and 19 AM radio stations.

FINDING AND STORING AM & FM STATIONS USING SEARCH.

You can use the SEARCH mode to automatically look for stations that are transmitting on in your area, and then use the STORE mode to enter them into the unit's memory.

First select the AM or the FM band using the AM FM button. Press MODE until the ► points to SEARCH on the Display Panel. Pressing the ▲ button starts the tuner searching up the frequency band pressing ▼ starts the tuner searching down the frequency band. When the tuner finds a broadcast signal of adequate strength (Shown by at least three sectors of the tuning strength meter and the lock • indicator illuminating) then the automatic search stops at that station. If you want to store that station as a preset, press STORE once and the current preset number



will be shown in the panel display. Use the ▲▼ buttons to select which preset number you wish to assign to the station and then press STORE again. This will store the frequency into the preset number being currently displayed. You can assign any station to any of the 19 presets in any order you wish. The search function will slow down when weak transmissions are registered. To stop the Search function at any of these stations press the MODE button. Press ▲ or ▼ to restart Search.

FINDING AND STORING AM & FM STATIONS USING MANUAL TUNE.

You can also manually TUNE stations and STORE them into the unit's memory.

First select the AM or the FM band using the AM FM button. Press MODE until the ► points to TUNE in the Display Panel. Pressing the ▲ button steps up the frequency band and pressing ▼ steps down the frequency band. The Tune Assist indicators ►◄ will illuminate when you are close to correctly tuning into the station and perfect tuning is indicated by the station lock indicator *. If you wish to store that station as a preset, press STORE once and the current preset number will be shown in the Display Panel. Use the ▲▼ buttons to select which preset number you wish to assign to the station and then press STORE again. This will store the station's frequency into the preset number being currently displayed. You can assign any station to any of the 19 presets in any order you wish.

RECALLING PRESET STATIONS.

To recall any of the preset stations select the required band using the AM FM button and then press MODE until the ► points to PRESET on the Display Panel. Press the ▲ or ▼ buttons to page up or down to the required Preset.

DOLBY PRO LOGIC AND SOUND SPACE (See also: Remote Control)

The Dolby Pro Logic and Sound Space buttons switches the 917 from stereo operation (Front Left and Right speakers only) to one of two types of surround mode:

The Sound Space modes are used to enhance stereo source material and the Dolby Pro Logic mode is used to play back Dolby Surround encoded movies, programmes and CDs.

15. DOLBY PRO LOGIC

The DOLBY PRO LOGIC button switches the 917 into Dolby Pro Logic mode. The Dolby Pro Logic decoder circuit will work with all inputs except for MONITOR 1 & 2, but will only function properly with material encoded in Dolby Surround. The button indicator illuminates when this mode has been selected.

16. DELAY

Press DELAY to set the overall delay time applied to the Surround channels to 15ms, 20ms, 25ms or 30ms. The delay time will be shown in the display panel for a few seconds after the DELAY button has been pressed. (See also: Setting The Surround Delay)

17. SOUND SPACE

The three Sound Space modes can be used to create a surround sound image from a stereo signal. The Sound Space circuits will work with all inputs except for MONITOR 1 & 2. The button indicator illuminates when each mode is selected.

CLUB: Press CLUB to re-create the sound of a small venue. This is more suitable for recordings of soloists, small ensembles and jazz.

HALL: Press HALL to create the sound of a larger concert hall. Try the HALL setting for larger orchestral works and rock.

STADIUM: Press STADIUM to re-create the sound of a large stadium. The STADIUM setting can be used for rock and pop and the largest orchestral works.

18. SIBILANCE FILTER

The tonal balance of some Laser Disc sound tracks can sound over-bright which leads to sibilance on speech (a hissing or splashy sound on consonants). The SIBILANCE FILTER reduces the extreme high frequency content, restoring a satisfactory tonal balance. The button indicator illuminates when the SIBILANCE FILTER is active. The filter only functions when the 917 is in Dolby Pro Logic or Sound Space Modes.

19. CDR

The 917 features the CONTROLLED DYNAMIC RANGE (CDR) circuit, which is used for listening at lower levels. This is a sophisticated dynamics controller that selectively raises the level of the quieter parts of the soundtrack, whilst leaving the louder parts unaltered.

Using CDR at lower listening levels (eg late at night), the apparent dynamics of the soundtrack can be maintained, without the dialogue becoming too quiet to hear comfortably.

The button indicator illuminates when CDR is active. CDR only functions when the 917 is in Dolby Pro Logic or Sound Space modes.

SETTING UP THE SURROUND SYSTEM.

To work at its best, the output levels of the 917's surround facilities need to be adjusted so that there is an even balance of sound from all the speakers in the system. The Delay time for the Surround speakers

Date:	SURROUND	SUB WOOFER	CENTER	DELAY (ms)
SETTING				
Date:	DOLBY 3CH/4CH	PHANTOM/NORMAL	SUB WOOFER	
SETTING				



also needs to be correctly set for your normal listening position.

The adjustment of speaker levels is done using the Test and Speaker Adjust functions on the Remote Control.

It is important first to correctly phase all the speakers in the system. Check that the positive (+) terminals of the amplifier speaker outputs are connected to the positive (+) connector on the each of the speakers.

Before starting the set-up procedure, ensure that the rear panel DOLBY PHANTOM/NORMAL, 3CH/4CH and SUBWOOFER SELECTOR switches are set correctly for your speaker configuration. If your power amplifiers have level controls, set them to a nominal line level setting (0dB) and make all further level adjustments using the 917's controls only.

TONE DEFEAT should be ON, MONO should be OFF and the BALANCE control set to the position normally used for stereo sources (usually the 12 o'clock position).

USING TEST TO SET UP THE SURROUND SYSTEM LEVELS.

With the speakers connected and the VOLUME turned down to zero, select DOLBY PRO LOGIC MODE and press TEST on the Remote Control. This generates a test signal that is fed to each of the speaker channels in turn (Left, Center, Right and Surround), so that each can be adjusted for equal loudness at your listening position. Test Signal Position indicators on the Display Panel show which speaker is being fed with the test signal.

Turn the VOLUME up until the signal is moderately loud through the Left and Right speakers. When the Test signal reaches the Center speaker, press the CENTER ▲ or ▼ buttons on the Remote Control to adjust the Center speaker's loudness to match the levels being produced by the Left and Right speakers. The relative level of the Center channel is shown in the Display Panel and can be changed in twelve 2dB steps marked between -6 and 6.

When you have finished adjusting the level of the Center channel, the Test signal will automatically continue switching between the speakers. If you are unhappy with your initial setting, repeat the procedure until the levels match.

Repeat the operation to set the Surround speaker level using the SURROUND ▲ or ▼ buttons on the Remote Control. The adjustment will affect the level of both Surround speakers simultaneously.

If it is not possible to adjust the centre or surround levels within the +/- 12dB range offered by the 917, check the power amplifier connectors or level settings (if fitted). These may need altering to match the output level of the 917 (see the power amplifier's instruction manual for the most suitable connector and level setting).

A more accurate adjustment can be made using a sound level meter, if available. Set the meter to 'Slow' and 'C-weighted' modes and re-check the settings with the meter placed in several different positions in the general listening area.

If a Sub Woofer is used on the system, use the SUB WOOFER ▲ or ▼ buttons on the Remote Control to set up the Sub Woofer level. With the test signal on the Front Left and Right speakers, the Sub Woofer

level should be adjusted so that the Sub Woofer speaker is audible, but does not dominate the sound. Sub Woofer levels can be later fine-tuned using programme material.

To leave Test mode and return to normal operation of the 917, press the Test button once more.

SETTING THE SURROUND DELAY.

Because the Surround speakers are usually closer to the listener than the Front speakers, there is a tendency for the ear to localise sounds to the rear, as the ear takes most notice of the sounds that arrive at the head first. To resolve this problem, the Dolby Pro Logic circuit includes a Surround sound delay. This ensures sounds coming from the Surround speakers always arrive at the listener's ears after the sounds from the Front speakers.

The exact amount of delay needed depends on the relative distances between the Front and Surround speakers to the listening position in the room.

Make a note of the distance between the Surround speakers and the listening area and the distance between the Front speakers and the listening area. Use the graph below and note where the two distances intersect. This will give the recommended Delay setting.

To adjust the Delay setting, put the 917 into Dolby Pro Logic mode and press DELAY on the front panel or the Remote Control. Continue pressing DELAY until the correct value is shown in the Display Panel. See Figure 3 for recommended distances.

Both Level and Delay settings apply to all Surround modes and are stored in the 917's memory. They are automatically recalled when the unit is switched on.

For your reference, use the boxes below to make a note of your settings. If they are accidentally altered, you can reset them without having to run the Test procedure.

REMOTE CONTROL

The RC917 Remote Control handles all the key functions of the 917 and has additional controls to remotely operate NAD Cassette and CD machines and will operate up to a distance of 16ft (5m).

Alkaline batteries are recommended for maximum operating life. The two AA (R6) batteries, are contained in the battery compartment at the rear of the Remote Control. When replacing batteries, check that they have been put in the right way round, as shown on the base of the battery compartment.

For ease of operation, the main functions of Listen & Monitor select, Volume and Mute are highlighted using gray buttons.

The subsidiary, mode, and set-up functions have black buttons. Power and Record (for an associated NAD cassette deck) are in red.

Refer to previous sections of the manual for descriptions of individual functions.

POWER. Switches the 917 between On and Standby.

VCR1. Selects VCR 1 as the active input.

VCR2. Selects VCR 2 as the active input.

FM. Selects the FM tuner as the active input.

AM. Selects the AM tuner as the active input.

LD. Selects the Laser Disc as the active input.

AUX. Selects the Aux as the active input.

TAPE 1. Selects Tape 1 as the active input.



TAPE 2. Selects Tape 2 as the active input.
CD. Selects CD as the active input.
MUTE. Mutes all outputs and displays MUTE on the Display Panel. Pressing MUTE again, restores sound at the original level.
TEST. Starts the Surround Set-up Test procedure.
CDR. Switches the Controlled Dynamic Range (CDR) circuit on or off.
PRESET ▲▼. Switches 917 to Tuner and pages through the Preset stations on AM or FM.
SEARCH ▲▼. Starts the Tuner Search function moving up or down the frequency band.
TUNE ▲▼. Selects the Manual Tune function, stepping up or down the frequency band.
VOLUME ▲▼. Increases or decreases the Volume setting, using the motorised front panel Volume control.
SURROUND ▲▼. Adjusts the relative level of the Surround speakers.
SUB WOOFER ▲▼. Adjusts the relative level of the Sub Woofer.
CENTER ▲▼. Adjusts the relative level of the Center channel speaker.
PRO LOGIC. Switches Dolby Pro Logic mode on or off.

STADIUM. Switches Stadium mode on or off.
HALL. Switches Hall mode on or off.
CLUB. Switches Club mode on or off.
SIBILANCE FILTER. Switches Sibilance Filter on or off.

CASSETTE DECK CONTROL (for use with NAD Cassette Deck)

STOP. Stops Play or Recording.
REC. Starts Recording.
PLAY. Starts Play.
◀◀. Rewind.
▶▶. Fast Forward.
PAUSE. Pauses Play or Record Modes.

CD PLAYER CONTROL (for use with NAD CD Player)

STOP. Stops Play.
◀◀. Scan back.
▶▶. Scan forward.
PLAY PAUSE. Play and Pause.
NEXT DISC. Next disc. (for NAD CD changers)

APPENDIX

A SHORT GUIDE TO SURROUND SOUND.

Since the middle of the 1970's, film companies have been making movies in increasing numbers in Dolby Stereo, the four channel surround sound system available in most movie theaters today.

Fortunately it is a simple operation to take the film's Dolby Stereo soundtrack and place it on a stereo VHS video tape, Laser Disc or Video-CD. The sound track does require some conversion for home use, and the domestic version of Dolby Stereo is called Dolby Surround.

Today, most video copies of movies also contain this surround information originally designed for the movie theater. As well as videos, Dolby Surround is also being used on TV programmes and on music CDs, and all of these can be decoded using your 917.

Unlike the quadrasonic systems which tried to produce pin-point sounds coming from all directions, Dolby Surround is designed to give you a clear front image with the Surrounds filling the room with atmospheric sound.

For best results, the Surround loudspeakers should not beam the sound directly at the listener. One way of achieving this is to use 'dipole' Surround speakers which aim the sound down the walls rather than directly into the room. An alternative is to use standard small loudspeakers for Surrounds, but not to point them directly at the listening position. It is always worth experimenting with various Surround speaker positions to see which works best in your room.

WHY HAVE A CENTER SPEAKER?

The Dolby Pro Logic decoder produces three separate outputs for the Front signals - Left, Center and Right. On most soundtracks, the sound effects and music are spread across all three Front channels but the dialogue is mainly fed to the Center channel only. Using a separate Center channel speaker will allow the dialogue to cut through even the biggest sound effects and musical scores. Having the sound spread across three Front speakers also stabilises the stereo image, making the usable listening area much bigger. If you are using the 917 with only two front speakers, setting the rear panel switch to PHANTOM will place the center information on both the Left and Right speakers. This creates the impression of a center channel sound source.

For best results, you should consider using a Center speaker. Ideally it should be the same type as the Left and Right speakers, although there are now many new speakers such as the NAD 808CC, which are specifically designed as Center channel add-ons for existing stereo systems.

CAUTION: Ensure that any speaker that is to be used near a TV or monitor is of the magnetically shielded type (see loudspeaker's instruction manual). Unshielded speakers used too close to a TV or monitor may cause colour distortions of the TV picture. (It is not normally possible to modify an unshielded speaker to work very close to a TV or monitor)

SPEAKER PHASE

In a home theatre system it is important that the three front speakers are all in phase compared to each other and that the surround speakers are in phase



compared to each other. Incorrect phase will produce a poor stereo image and an apparent lack of bass.

Make sure that all the red + connectors on the power amplifier speaker outputs are connected to the red + connector on the loudspeaker.

If you are using a mix of amplifiers or speakers from different manufacturers or using amplifiers in 'bridge' mode then it is possible that the phase can be internally reversed in some amplifiers or speakers, so you must check for correct phase by listening.

SYSTEM EXAMPLES

The 917 can be used at the heart of a broad range of surround sound systems. Here are two possible systems configurations; one basic and one advanced.

A SIMPLE SET-UP USING THE 917.

This system uses the 917 with a pair of stereo power amplifiers, such as the NAD 214 or 216, and connections to a video, CD, cassette deck and a TV.

The first power amplifier is connected to the FRONT outputs and the second stereo power amplifier is connected to the SURROUND outputs.

Since there are Surrounds, such as the NAD 805C, but no Center channel speaker, the Rear Panel DOLBY switches are set to 4CH and PHANTOM.

The CD and Cassette deck are connected to CD and TAPE 1 (IN & OUT) respectively.

The VCR machine is connected to VCR1 as it will be used for playback-only through the system, with video recording from the VCR's internal tuner.

The TV's Video Line Input is connected to MONITOR. See Fig. 3 for a diagrammatic lay-out of this system.

A MORE COMPLEX SET-UP USING THE 917.

This set-up uses the 917 as the center-piece of a sophisticated Home Theater system. As well as the standard audio sources, this system has also a VCR, a Laser Disc player and a games console connected as A/V sources. The output of the 917 goes to a Home Theater six channel power amplifier, such as the NAD 916, which is driving three Front channel speakers, the Surround speakers and a Sub Woofer. The Multi-Room output is feeding a hi-fi system in a second room, which uses the amplifier's NAD-Link to send remote control information back to the 917.

The six channel power amplifier is connected to the FRONT, SURROUND, CENTER and SUB WOOFER outputs. Since there are both Surround and Center channel speakers, the Rear Panel DOLBY switches are set to 4CH and NORMAL.

The large Sub Woofer being used does not have its own filter circuits, so the Sub Woofer switch is set to 60Hz.

The CD and Cassette deck are connected to CD and TAPE 1 (IN & OUT) respectively.

The Laser Disc player is connected to the LD audio and video inputs. The games console, which requires playback only, is connected to the VCR1 audio and video inputs.

The VCR machine is connected to VCR2 which has audio/video INPUTS and OUTPUTS to enable recording from the other video sources.

To use the Multi Room facility, the MULTI ROOM

OUT is connected via high quality phono leads to the Aux Input on the hi-fi system in the second room. The NAD-Link OUT connector on the second hi-fi amplifier is connected to NAD-Link IN on the 917 so that it can be remotely controlled from the second room.

The TV's Video Line Input is connected to MONITOR. See Figure 4 for a diagrammatic lay-out of this system.

 GB

TROUBLESHOOTING

NO SOUND

Power AC lead unplugged or power not switched on.
 Monitor 1 or 2 selected.
 Power amplifiers not switched on or disconnected.
 Mute on.
 Internal fuse blown.

Check AC lead.
De-select Monitor mode.
Check power amplifiers.
Switch off Mute.
Consult dealer.

NO SOUND ONE CHANNEL

Balance control not centered.
 Speaker not properly connected or damaged.
 Input leads or leads to Power amp disconnected or damaged.

Center Balance control.
Check connections and speakers.
Check leads and connections.

DOLBY PRO LOGIC AND SOUND SPACE MODES INOPERATIVE

Monitor 1 or Monitor 2 selected.

Deselect Monitor.

NO SOUND ON SURROUND CHANNELS

A surround mode has not be selected.
 MONO button switched on.
 Sound source is in Mono.

Select Dolby Pro Logic or Sound Space modes.
Switch 917 to STEREO
Test system with known stereo or Dolby Surround material.
Check speakers and connections.
Check power amplifiers and connections.
Switch to 4CH.

Speakers not properly connected or damaged.
 Surround power amplifiers not switched on or disconnected.
 Rear panel Dolby switch set to 3CH.

WEAK BASS/ DIFFUSE STEREO IMAGE

Speakers wired out of phase.

Check connections to all speakers in the system.

TEST SIGNAL POSITION DOES NOT MATCH TEST SIGNAL INDICATOR LIGHTS.

Power amplifier or speakers connected to the wrong outputs.

Check connections to all amplifier and speaker channels.

REMOTE CONTROL NOT WORKING

Batteries flat, or incorrectly inserted.
 IR transmitter or receiver windows obstructed.

Check or replace batteries.
Remove obstruction.

TUNER NOISE

Hiss - Weak signal.

Check signal strength meter. Check station tuning. Adjust or replace antenna.

Distortion - Multipath signals.
 Whistles or buzzes on FM & AM: Interference from other electrical sources - computers, games consoles.
 Whistles or buzzes on AM: Interference from fluorescent lighting or electrical motors.

Check station tuning. Adjust or replace antenna.
Check station tuning. Switch off or move the source of the electrical noise.
Check station tuning. Adjust or replace AM antenna.