

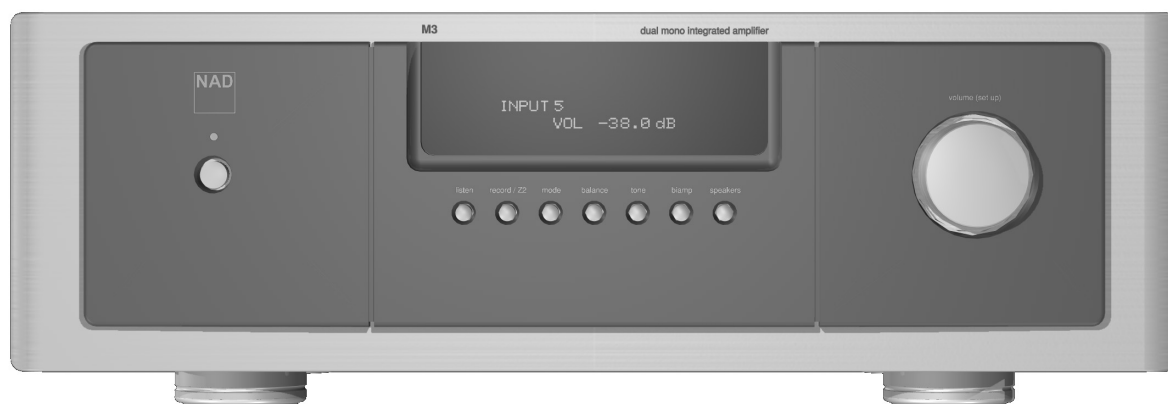

M3

Dual Mono Integrated Amplifier



Owner's Manual
Manuel d'Installation
Bedienungsanleitung
Gebruikershandleiding
Manual del Usuario
Manuale delle Istruzioni
Manual do Proprietário
Bruksanvisning

ENGLISH

FRANÇAIS

DEUTSCH

NIEDERLANDS

IMPORTANT SAFETY INSTRUCTIONS

- Save these instructions for later use.
- Follow all warnings and instructions marked on the audio equipment.

1 Read instructions - All the safety and operating instructions should be read before the product is operated.

2 Retain instructions - The safety and operating instructions should be retained for future reference.

3 Heed Warnings - All warnings on the product and in the operating instructions should be adhered to.

4 Follow Instructions - All operating and use instructions should be followed.

5 Cleaning - Unplug this product from the wall outlet before cleaning. Do not use liquid cleaners or aerosol cleaners. Use a damp cloth for cleaning.

6 Attachments - Do not use attachments not recommended by the product manufacturer as they may cause hazards.

7 Water and Moisture - Do not use this product near water-for example, near a bath tub, wash bowl, kitchen sink, or laundry tub; in a wet basement; or near a swimming pool; and the like.



8 Accessories - Do not place this product on an unstable cart, stand, tripod, bracket, or table. The product may fall, causing serious injury to a child or adult, and serious damage to the product. Use only with a cart, stand, tripod, bracket, or table recommended by the manufacturer, or sold with the product. Any mounting of the product should follow the manufacturer's instructions, and should use a mounting accessory recommended by the manufacturer.

9 A product and cart combination should be moved with care. Quick stops, excessive force, and uneven surfaces may cause the product and cart combination to overturn.

10 Ventilation - Slots and openings in the cabinet are provided for ventilation and to ensure reliable operation of the product and to protect it from overheating, and these openings must not be blocked or covered. The openings should never be blocked by placing the product on a bed, sofa, rug, or other similar surface. This product should not be placed in a built-in installation such as a bookcase or rack unless proper ventilation is provided or the manufacturer's instructions have been adhered to.

11 Power Sources - This product should be operated only from the type of power source indicated on the marking label. If you are not sure of the type of power supply to your home, consult your product dealer or local power company.

- **Main Power Disconnect;** When the power switch is in the Off position, the integrated amplifier is not completely disconnected from the main power. The primary method of isolating the integrated amplifier from the mains supply is to disconnect the mains plug. Ensure that the mains plug remains accessible at all times. When installing the product, ensure that the plug is easily accessible.
- **Non-use Period;** Unplug the AC power cord from the AC outlet if the unit will not be used for a long period of time such as several months or more.

12 Grounding or Polarization - This product may be equipped with a polarized alternating-current line plug (a plug having one blade wider than the other). This plug will fit into the power outlet only one way. This is a safety feature. If you are unable to insert the plug fully into the outlet, try reversing the plug. If the plug should still fail to fit, contact your electrician to replace your obsolete outlet. Do not defeat the safety purpose of the polarized plug.

13 Power-Cord Protection - Power-supply cords should be routed so that they are not likely to be walked on or pinched by items placed upon or against them, paying particular attention to cords at plugs, convenience receptacles, and the point where they exit from the product.

14 Outdoor Antenna Grounding - If an outside antenna or cable system is connected to the product, be sure the antenna or cable system is grounded so as to provide some protection against voltage surges and built-up static charges. Article 810 of the National Electrical Code, ANSI/NFPA 70, provides information with regard to proper grounding of the mast and supporting structure, grounding of the lead-in wire to an antenna discharge unit, size of grounding conductors, location of antenna discharge unit, connection to grounding electrodes, and requirements for the grounding electrode.

NOTE TO CATV SYSTEM INSTALLER

- This reminder is provided to call the CATV system installer's attention to Section 820-40 of the NEC which provides guidelines for proper grounding and, in particular, specifies that the cable ground shall be connected to the grounding system of the building, as close to the point of cable entry as practical.

15 Lightning - For added protection for this product during a lightning storm, or when it is left unattended and unused for long periods of time, unplug it from the wall outlet and disconnect the antenna or cable system. This will prevent damage to the product due to lightning and power-line surges.

16 Power Lines - An outside antenna system should not be located in the vicinity of overhead power lines or other electric light or power circuits, or where it can fall into such power lines or circuits. When installing an outside antenna system, extreme care should be taken to keep from touching such power lines or circuits as contact with them might be fatal.

17 Overloading - Do not overload wall outlets, extension cords, or integral convenience receptacles as this can result in a risk of fire or electric shock.

18 Object and Liquid Entry - Never push objects of any kind into this product through openings as they may touch dangerous voltage points or short-out parts that could result in a fire or electric shock. Never spill liquid of any kind on the product.

19 Damage Requiring Service - Unplug this product from the wall outlet and refer servicing to qualified service personnel under the following conditions:

- When the power-supply cord or plug is damaged.
- If liquid has been spilled, or objects have fallen into the product.
- If the product has been exposed to rain or water.
- If the product does not operate normally by following the operating instructions. Adjust only those controls that are covered by the operating instructions as an improper adjustment of other controls may result in damage and will often require extensive work by a qualified technician to restore the product to its normal operation.
- If the product has been dropped or damaged in any way.
- When the product exhibits a distinct change in performance-this indicates a need for service.

20 Replacement Parts - When replacement parts are required, be sure the service technician has used replacement parts specified by the manufacturer or have the same characteristics as the original part. Unauthorized substitutions may result in fire, electric shock, or other hazards.

21 Safety Check - Upon completion of any service or repairs to this product, ask the service technician to perform safety checks to determine that the product is in proper operating condition.

22 Wall or Ceiling Mounting - The product should be mounted to a wall or ceiling only as recommended by the manufacturer.

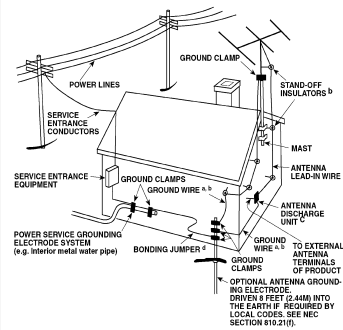

Introduction

SAFETY INFORMATION

ENGLISH



WARNING



TO PREVENT FIRE OR SHOCK HAZARD, DO NOT EXPOSE THIS APPLIANCE TO RAIN OR MOISTURE. THE LIGHTNING FLASH WITH ARROWHEAD SYMBOL, WITHIN AN EQUILATERAL TRIANGLE, IS INTENDED TO ALERT THE USER TO THE PRESENCE OF UNINSULATED "DANGEROUS VOLTAGE" WITHIN THE PRODUCT'S ENCLOSURE THAT MAY BE OF SUFFICIENT MAGNITUDE TO CONSTITUTE A RISK OF ELECTRIC SHOCK TO PERSONS.



THE EXCLAMATION POINT WITHIN AN EQUILATERAL TRIANGLE IS INTENDED TO ALERT THE USER TO THE PRESENCE OF IMPORTANT OPERATING AND MAINTENANCE (SERVICING) INSTRUCTIONS IN THE LITERATURE ACCOMPANYING THE APPLIANCE

CAUTION

Changes or modifications to this equipment not expressly approved by NAD Electronics for compliance could void the user's authority to operate this equipment.

CAUTION REGARDING PLACEMENT

To maintain proper ventilation, be sure to leave a space around the unit (from the largest outer dimensions including projections) equal to, or greater than, shown below.

Left and Right Panels : 10 cm

Rear Panel : 10 cm

Top Panel : 50 cm

IMPORTANT INFORMATION FOR UK CUSTOMERS

DO NOT cut off the mains plug from this equipment. If the plug fitted is not suitable for the power points in your home or the cable is too short to reach a power point, then obtain an appropriate safety approved extension lead or consult your dealer. If, nonetheless, the mains plug is cut off, REMOVE THE FUSE and dispose of the PLUG immediately, to avoid possible shock hazard by inadvertent connection to the mains supply. If this product is not provided with a mains plug, or one has to be fitted, then follow the instructions given below:

IMPORTANT

DO NOT make any connection to the larger terminal which is marked with the letter 'E' or by the safety earth symbol or coloured GREEN or GREEN AND YELLOW.

The wires in the mains lead on this product are coloured in accordance with the following code:

BLUE - NEUTRAL

BROWN - LIVE

As these colours may not correspond with the coloured markings identifying the terminals in your plug, proceed as follows:

The BLUE wire must be connected to the terminal marked with the letter 'N' or coloured BLACK.

The BROWN wire must be connected to the terminal marked with the letter 'L' or coloured RED

When replacing the fuse, only a correctly rated and approved type should be used, and be sure to re-fit the fuse cover.

IF IN DOUBT CONSULT A COMPETENT ELECTRICIAN

This product is manufactured to comply with the radio interference requirements of EEC DIRECTIVE 89/68/EEC and 73/23/EEC

NOTES ON ENVIRONMENTAL PROTECTION

At the end of its useful life, this product must not be disposed of with regular household waste but must be returned to a collection point for the recycling of electrical and electronic equipment. The symbol on the product, user's manual and packaging, point this out.

The materials can be reused in accordance with their markings. Through re-use, recycling of raw materials, or other forms of recycling of old products, you are making an important contribution to the protection of our environment.

Your local administrative office can advise you of the responsible waste disposal point.

RECORD YOUR MODEL NUMBER (NOW, WHILE YOU CAN SEE IT)

The model and serial number of your new Integrated Amplifier located on the back of the cabinet. For your future convenience, we suggest that you record these numbers here:

Model No. : _____ Serial No. : _____

ANALOG SOUND, DIGITAL CONTROL

The M3 is NAD's concept of the ideal musical companion, capable of transporting the listener to that place where the music simply exists in its own perfect space. For this task we have pushed classical analog circuit design to unprecedented levels of performance. The total lack of audible noise and distortion is the result of some very sophisticated analog engineering, and rather surprisingly, the use of digital control.

Freed of the constraints of traditional analog switches, NAD's Director of Advanced Development, Bjorn Erik Edvardsen devised an architecture using precision 1% resistors controlled by digital switches for all the level adjustments required for volume control, balance control and tone control. (Yes we still believe in tone controls - more on that later.) Input selection is via precision sealed reed relays. A major advantage of this architecture, in addition to its extremely precise performance, is the ability to place controls in the most advantageous physical position within the circuit. The signal never has to travel to the front panel for switching, as with traditional amplifier designs. Getting to the infinitesimal levels of noise and distortion of the M3 requires very careful circuit layout, as only tiny changes in the signal path can have large effects on performance. Keeping signal paths as short as possible is also greatly aided by the use of SMD (miniature surface mount) components and multi-layer PCBs (circuit boards).

LUXURIOUS STYLING AND INTELLIGENT CONTROL

The design brief reads: "The industrial design must create a physical presence that is powerful, dynamic, and solid, yet refined and elegant". We wanted a design that will still look fresh and new a decade from now, a design with classic proportions and understated details. We also wanted an amplifier that was not only easy to operate, but also very flexible and complete in its control options.

Unlike many high performance amplifiers, the M3 includes a full suite of convenience features. Speaker switching for two pairs of speakers and very flexible tone controls are provided, as is a Zone 2 output with its own independent set of commands and dedicated ZR3 remote control. Front panel controls use a multi-function knob and buttons to quickly navigate all amplifier functions. All operating conditions are clearly displayed on a 2 line dot matrix VFD display. Direct access is available to many functions via the M3 remote handset. The M3 handset also features basic controls for the matching NAD DVD/SACD player.

Performance features include a multi-stage precision volume attenuator with 0.5dB steps and a range of 87.5dB, a remote balance control with 0.5dB steps, and a Mode control that allows stereo, left only, right only, and mono settings. Tone controls offer bass and treble adjustment, as well as a 'spectral tilt' option that is highly effective at correcting the tonal balance of many recordings by simultaneously increasing the bass and decreasing the treble (and vice versa) to create a warmer (or cooler) balance. We have also included a second set of preamp outputs and a switchable high pass filter for the internal amplifier, to allow easy implementation of an active subwoofer or biamplication.

The rugged chassis is built using thick 2mm mild steel plates with a front panel employing extruded aluminium and die-cast zinc in its construction. Special attention was paid to the control of mechanical resonance, as this can affect sonic performance. Special isolation feet use aluminium and silicon rubber in a vibration damping configuration. All signal connectors are heavy duty gold plated types specifically engineered for the NAD Masters Series components. Finished inside and out, the M3 utilizes powder coating and advanced automotive paint finishes, creating an enduring and elegant mechanical package.

PREAMP DESIGN

The preamp uses all discrete low noise high impedance J-FET buffer amps and very high quality reed relay switches at the preamp input. Special high current low output impedance Class A gain modules provide tremendous dynamic headroom and high output current, combined with a exceptional S/N ratio in excess of -100dB (IHF).

Introduction

About the M3 Dual Mono Integrated Amplifier:

The volume attenuator is very unique in that it uses discrete 1% precision resistors that keep impedance (and noise) very low. It is arrayed in 3 stages to reduce the residual noise in each amplifying stage and prevent the 'cascade effect' of noise that is present in most preamp designs. This circuit also provides the balance control, and as a result channel separation is superb and inter-channel cross talk is virtually eliminated. These resistor arrays are switched using 15 volt digital switches under software control, keeping all attenuation at the ideal point in the circuit architecture.

Low impedance stepped tone controls provide +/- 5 db of boost/cut in the bass and treble regions, or can be configured to provide variable slope, or 'spectrum tilt' at +/- 3dB per octave.

Biamp function allows the use of a second amplifier or active subwoofer **PREOUT 1**, and offers a high pass filter function on **PREOUT 2**, with selectable 40Hz, 60Hz, 80Hz, 100Hz or Full Range options. These are analog 2nd order filters configured around the low impedance differential Class A output stage of the preamp. This output stage also employs proprietary distortion cancellation circuitry.

A balanced line input is also provided using identical JFET buffers feeding a discrete differential amp and yielding common mode rejection in excess of 80dB.

Separately regulated DC supplies are derived from the dual mono power supply. Copper buss bars and discrete regulators keep circuit noise to an absolute minimum throughout. The display and digital functions operate from an independent power supply to prevent any interference with the analog signal path.

POWER AMP HIGHLIGHTS

The M3 features a Dual Mono design with separate unregulated and discrete regulated supplies for different stages of the 2 channels. The custom wound Toroidal transformers use proprietary magnetic shielding technology. High current rectifiers feed low ESR 105C filter capacitors.

NAD's PowerDrive technology measures load impedance continuously on each channel and adjusts the power supply voltage for maximum undistorted dynamic power into the connected speaker at all times and under all operating conditions. The signal processor also continuously measures temperature and average long term power and, based on this information, chooses the optimum voltage.

PowerDrive allows the M3 to sound far more powerful than its already impressive 180 watt per channel rating would suggest. Totally effortless sound, even at elevated levels, is the hallmark of the PowerDrive amplifier.

The M3 utilizes a wideband current-mode Class A voltage amp featuring large open loop compensated bandwidth, and running from low noise stabilised power supplies. NAD's patented current amp output stage starts with < 0.02 % static and dynamic distortion open loop (before feedback); even into 3 ohms at 20-20k at all levels. By utilizing small amounts of feedback the circuit returns distortion levels at all audible frequencies that are at limit of measurement - less than 0.002%!

The super rugged output stage features 4 pairs of 150W discrete bipolar output transistors per channel, for 50A peak undistorted output current. Massive heat sinking assures a lifetime of trouble free operation.

MAIN FEATURES:

- Discrete high input impedance balanced input amp with greater than 70dB Common Mode rejection ratio across the entire frequency range.
- High input impedance class-A amplifiers in the main signal path.
- Proprietary stepped-distributed low impedance volume control for ultra low noise/distortion at all volume levels.
- PowerDrive current-mode power amplifier and NAD's patented output stage with ultra low distortion that drive low impedance loads.
- Separate low-noise low-impedance regulated supplies for each channel's inputs and driver stages.

WHAT'S IN THE BOX:

Packed with your M3 Dual Mono Integrated Amplifier you will find:

- A removable AC cable
- The M3 remote control with batteries
- The ZR3 second zone remote control with battery
- This Owner's Manual

SAVE THE PACKING:

Please save the box and all of the packaging in which your M3 arrived. Should you move or otherwise need to transport your integrated amplifier, this is by far the safest container in which to do so. We've seen too many otherwise perfect components damaged in transit for lack of a proper shipping carton, so please: Save that box!

QUICK START:

1. Connect the speakers to the rear Speaker sockets and sources to the relevant rear input sockets.
2. Plug in the AC Mains cable to the back IEC socket of the M3.
3. Switch to ON, the POWER button on the rear panel, to turn the M3 to standby.
4. Press power button on the front panel to turn on the M3.
5. Press and toggle the listen button to select the source.

A NOTE ON INSTALLATION

Install this unit on any level surface that is strong enough to support its weight. Avoid placing the unit in direct sunlight or near sources of heat and damp. Do not locate adjacent to or directly above the amplifier a turntable (especially one with a moving-coil pick-up cartridge) or a TV should since the M3's power transformers generate a significant magnetic hum field.

The heat-sink fins make it awkward to lift the M3 by grasping the left and right sides. You may find it more practical to place your hands under the front and rear panels. Much of the M3's weight is near the front panel.

CAUTION: The amplifier's weight must always rest on its bottom feet. Never put the amplifier down on its rear panel, with its front panel facing up. Doing so risks damage to the input/output connectors.

The integrated amplifier generates some heat, even when idling, requiring internal and external ventilation. Allow adequate ventilation. Do not place it in an enclosed position such a bookcase or cabinet that may impede the air-flow through the ventilation slots.

Do not obstruct by papers or articles of clothing the ventilation slots on the top cover. Furthermore, if you want to locate the amplifier on a carpeted floor, place a board under the amplifier in order to prevent it from sinking into the carpet, blocking the air inlets on its bottom.

Identification of controls

FRONT PANEL CONTROLS (FIGURE 1)

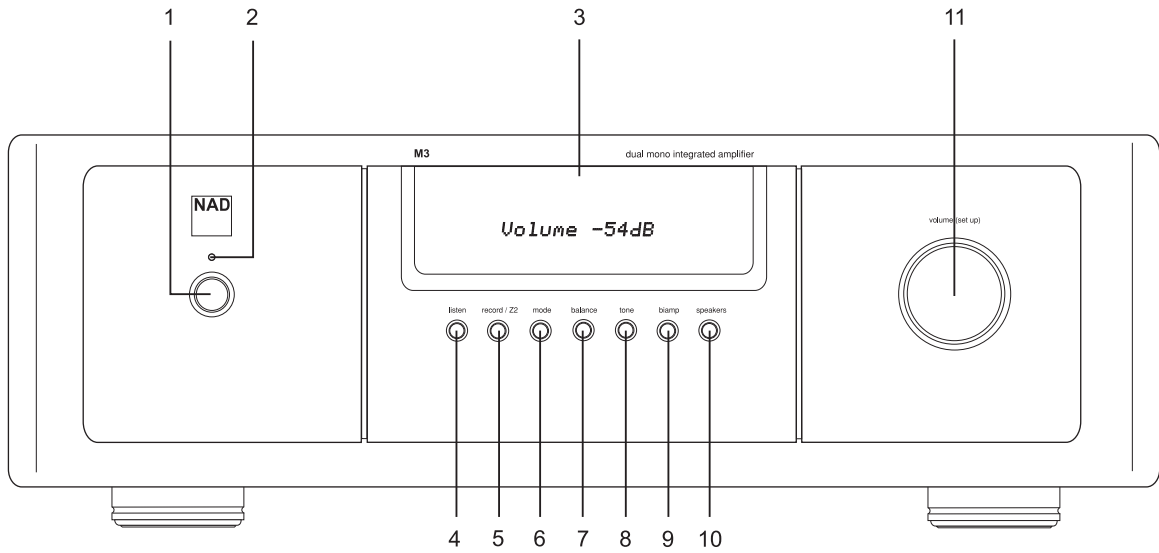

REAR PANEL CONNECTIONS AND CONTROLS (FIGURE 2)

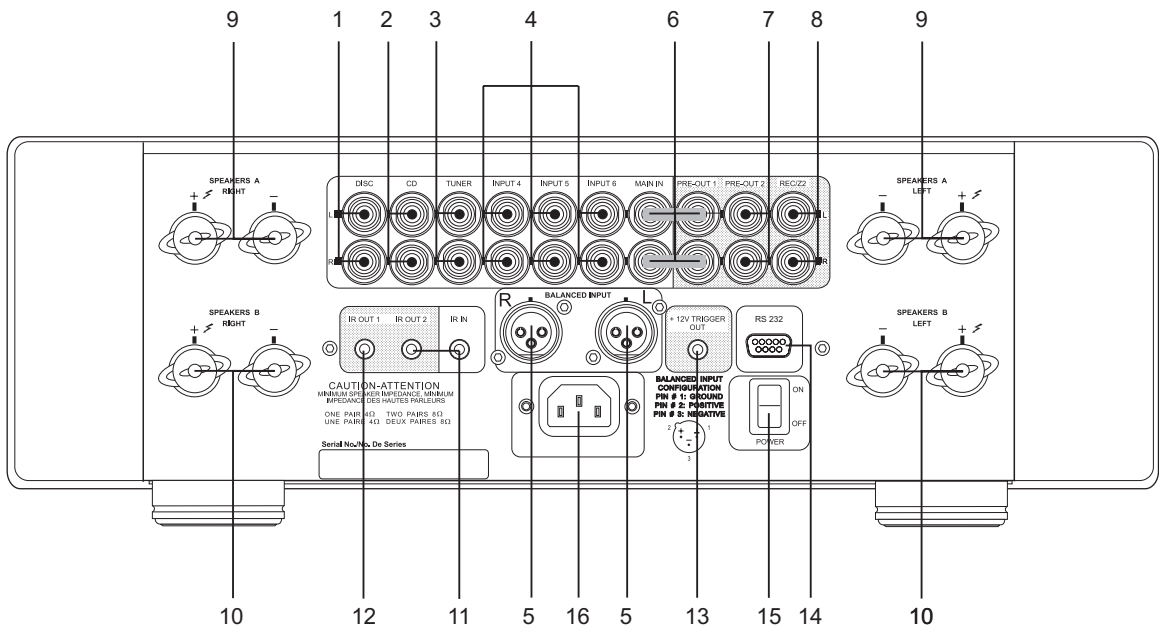
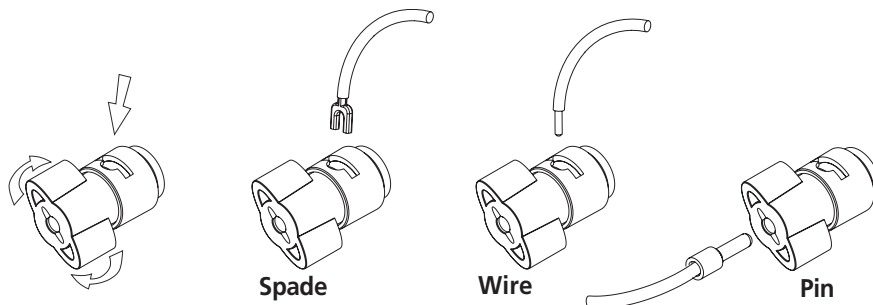
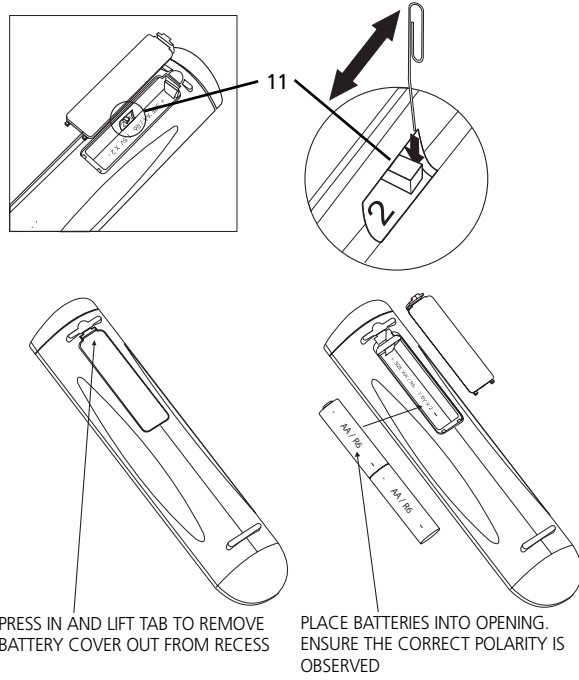
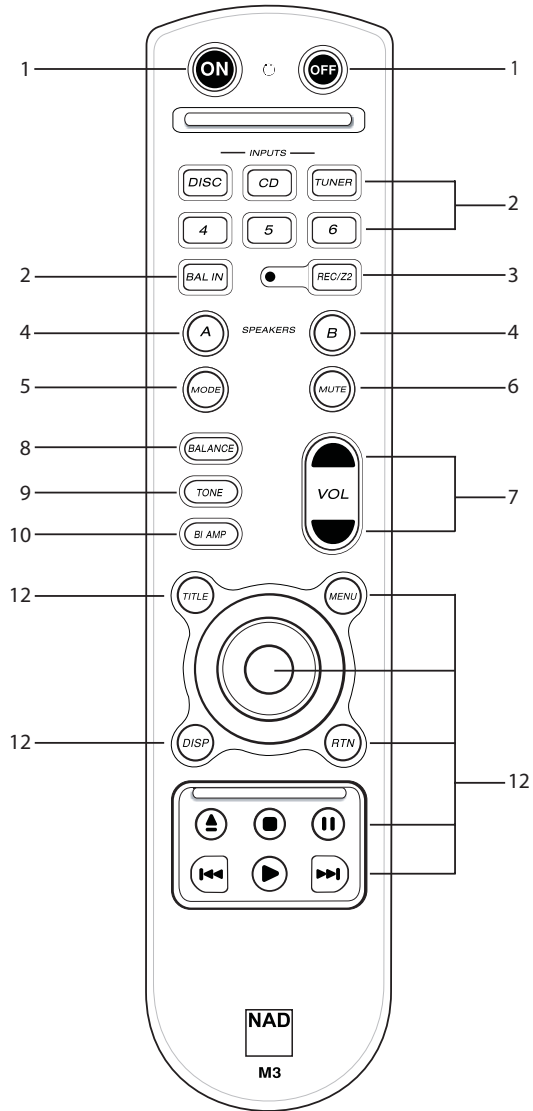

FIGURE 3



Identification of controls

M3 REMOTE CONTROL (FIGURE 4)



ENGLISH

ZR3 REMOTE CONTROL (FIGURE 5)

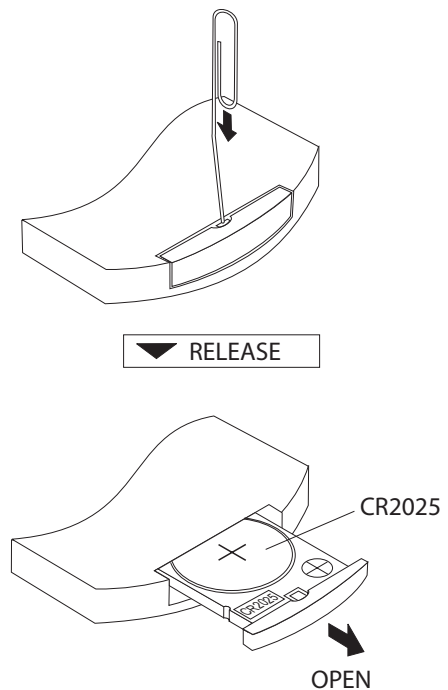
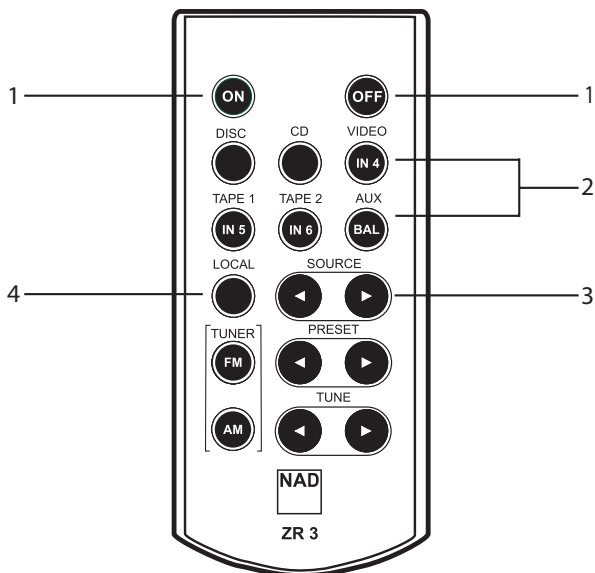

Identification of controls

About the M3 Dual Mono Integrated Amplifier:

FRONT PANEL CONTROLS (FIGURE 1)

- 1. Standby Button:** The Standby Button turns on and to standby the M3. This button will only function when the Status Condition LED is either blue representing the on-state, or amber representing the standby state.
- 2. Status Condition L.E.D.:**
 - Standby:** When this L.E.D. is amber the M3 is in the standby state.
 - On:** When this L.E.D. is blue the M3 is operating in the on-state.
 - Protection:** When this L.E.D. is red the M3 is in a protection state.
The M3 has sensors for abnormally high internal heat and signal level conditions that would damage either the M3 or speakers. When these conditions return to normal, the M3 reverts to the on-state. In the event the Status Condition L.E.D. is red and PROTECT displays in the VFD for longer than 5 minutes; switch off the M3 via the rear panel POWER switch, check all speaker cables and connections for short-circuits. Resume normal operation. If the Status Condition L.E.D. continues to light red and PROTECT displays in the VFD, contact qualified NAD service personnel for repair.
- 3. Vacuum Florescent Display (VFD):** The VFD provides visual information on all of the M3's important modes, settings, and functions for both main and second zone locations.
- 4. listen (input selection):** Press the listen button to select an input. A press longer than one second will advance the input selection to the next input as follows; DISC, CD, TUNER, INPUT 4, INPUT 5, INPUT 6, BALANCED and then return to DISC. Release the listen button to stop the sequence.

Assigning User Names (input selection): Renaming inputs is advantageous when using auxiliary equipment not representing the default inputs. For example, a CD-player with balanced outputs would connect to the balanced input. Rename the balanced input to CD-Player as follows;

Press and hold simultaneously the **listen** and **record / Z2** buttons until the cursor flashes. Rotate the **volume (set up)** control to the letter "C" then press the **listen** button to lock the selection and advance the cursor. Continue the procedure for the remaining letters of the name. Press the **record / Z2** button to save the new user name.

NOTES: There is a maximum of 20 letters to each name. The variables are; lowercase letters, uppercase letters, numbers, and miscellaneous punctuation symbols.
Record each name you assign into the chart on page 17 to aid you for future reference in the event you wish to change the hook-up and assignment of the inputs.

- 5. record / Z2 (second zone output):** Press the **record / Z2** button to select the input as the recording source. A press longer than one second will advance the source selection to the next input as follows; OFF, DISC, CD, TUNER, INPUT 4, INPUT 5, INPUT 6, BALANCED, LOCAL, and then return to OFF. Release the **record / Z2** button to stop the sequence. Furthermore, the ZR3 remote control will allow direct selection of inputs (see ZR3 Remote Control).

NOTE: The record / Z2 can monitor all inputs. The record / Z2 will maintain its last state even if the M3 is set to standby. The M3 must be in its on state in order to use the record / Z2.

6. mode: The mode selector function is a convenient way to test the set up of the M3. For example, use the Mono mode to check the speakers phase. Setting the mode to Left or Right allows one to easily balance left signal inputs with right signal inputs.

Press the mode button to toggle through the four listening modes. A press longer than one second will advance the mode selection to the next state as follows; STEREO, MONO, LEFT, RIGHT, and then return to the STEREO listening mode. Release the mode button to stop the sequence.

7. balance: Adjust LEFT and RIGHT balance simultaneously using the volume (set up) control. Both LEFT and RIGHT levels are adjustable between +/- 9.5 dB
To adjust balance; press the balance button once and then within 5 seconds, rotate the volume (set up) control to adjust the either the LEFT or RIGHT balance level. After about 5 seconds, the balance menu will switch off saving the balance settings in memory.

8. tone: Press the **tone** button to activate or deactivate the tone controls. A press longer than one second will toggle the tone option between TONE ACTIVE and TONE DEFEAT. To bypass bass, treble, and spectral tilt controls completely, select TONE DEFEAT (direct bypass of all analogue filters). To enable TONE ACTIVE, toggle the **tone** button to display TONE ACTIVE and then release the **tone** button. Then within a few moments the tone controls will display. Then press the **tone** button to toggle through bass, treble and tilt functions.

Selecting TONE ACTIVE allows one to adjust the bass, treble, and spectral tilt settings of the M3 via the volume (set up) control. Bass and treble levels are adjustable between +/- 5dB. The spectral tilt adjustment allows for simultaneous +/-3dB bass and treble offsets. When adjusting bass and treble levels, the spectral tilt value will remain 0dB. When adjusting the spectral tilt, the bass and treble values will follow the spectral tilt adjustment simultaneously. See figures 6 & 7, examples of bass, treble, and tilt frequency response diagrams.

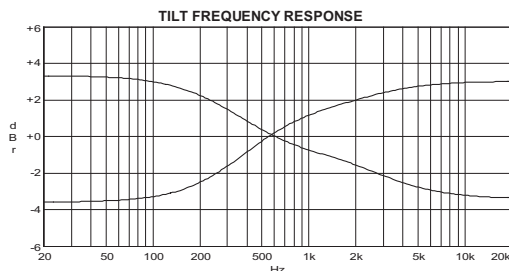

FIGURE 7

9. biamp (crossover frequency selection): If one uses smaller shelf-type speakers, in conjunction with a powered subwoofer (refer to **PRE OUT 2** section under Rear Panel Connections and Controls), the M3 allows the configuration of the speaker crossover frequency to match the bass response of the speakers. Press the **biamp** button to toggle through the filter sequence. A press longer than one second will advance the crossover frequency selection as follows; BIAMP CROSSOVER FULL RANGE, HIGH PASS 40 Hz, HIGH PASS 60 Hz, HIGH PASS 80 Hz, HIGH PASS 100 Hz, and then return to FULL RANGE. Release the **biamp** button to stop the sequence. See figure 8 examples of the crossover frequency response diagram. For connection of a subwoofer see Rear Panel Connections and Controls; **PRE OUT 2**.

10. speakers: The M3 has two sets of speaker terminals A and B. One may switch on or off both sets together or separately. Press the **speakers** button to toggle through the four speaker selections. A press longer than one second will advance the speaker selection as follows; SPEAKERS A, SPEAKERS B, SPEAKERS A+B, SPEAKERS Off, and then return to the SPEAKER A selection. Release the speakers button to stop the sequence. Refer to biamp for setting up the crossover frequency above.

11. volume (set up): Use the **volume (set up)** control for; volume control, balance adjustment, tone controls, and renaming inputs. The default turn-on volume level setting for the volume is -20 dB. The turn on volume level will always revert to -20 dB if the volume level is set to greater than -19 dB before switching to standby.

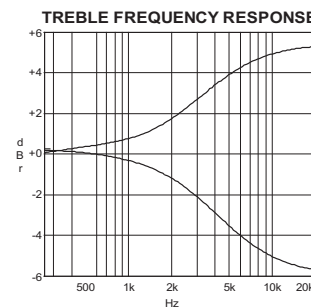
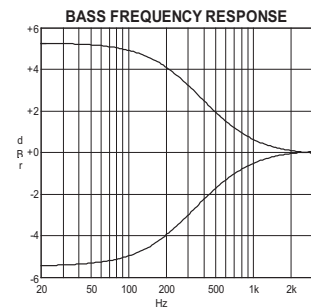

FIGURE 6

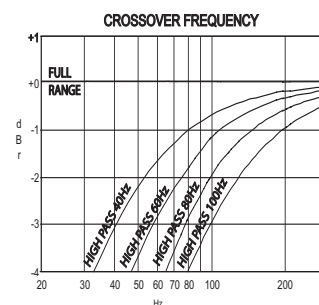

FIGURE 8

Setup

About the M3 Dual Mono Integrated Amplifier:

REAR PANEL CONNECTIONS AND CONTROLS (FIGURE 2)

1. **DISC:** Connect line-level audio Left and Right to this input from a video disc or DVD-player.
2. **CD:** Connect line-level audio Left and Right to this input from a CD-player
3. **TUNER:** Connect line-level audio Left and Right to this input from a tuner (radio).
4. **INPUT 4-6:** Connect any audio source to these line-level audio Left and Right inputs. Reassign new names by following the Assigning User Names procedure under the Front Panel Controls section.
5. **BALANCED:** Connect XLR audio source to these inputs. Make sure the configuration is standard as follows; pin 1 is chassis ground (earth), pin 2 is signal live, and pin 3 is signal return. Reassign a name to this input by following the Assigning User Names procedure under the Front Panel Controls section.
6. **MAIN IN/PRE OUT 1:** The primary link between the M3's dual mono-block preamplifier and dual mono-block amplifier is by these jumpers. This connection supplies the full frequency range output.

NOTE: The **biamp** (Crossover Frequency Selection) settings do not affect this output.

PRE OUT 2: This secondary preamplifier output follows the volume level of the **PRE OUT 1**. Adjust the **biamp** high pass frequency settings for **PRE OUT 2** using the **biamp** (Crossover Frequency Selection) to match the frequency response of the speakers connected to the M3's speakers A or B terminals.

Biamp Connection: If you choose to use the **biamp** feature of the M3 first power off the M3, and then disconnect the M3 from the mains voltage. Disconnect the **MAIN IN/PREOUT 1** jumper (Figure 9-1) for each channel. Connect the **PRE OUT 1** output left and right to an active subwoofer (Figure 9-2) using high quality RCA-type patch cables. Using a set of short high quality RCA-type patch cables, jumper from **PREOUT 2** to **MAIN IN** both left and right channels (Figure 9-3).

If available on the subwoofer, match the subwoofer crossover settings with the biamp crossover settings of the **PRE OUT 2**. Refer to Front Panel Controls section biamp control, for the selection of crossover frequencies available.

FIGURE 9

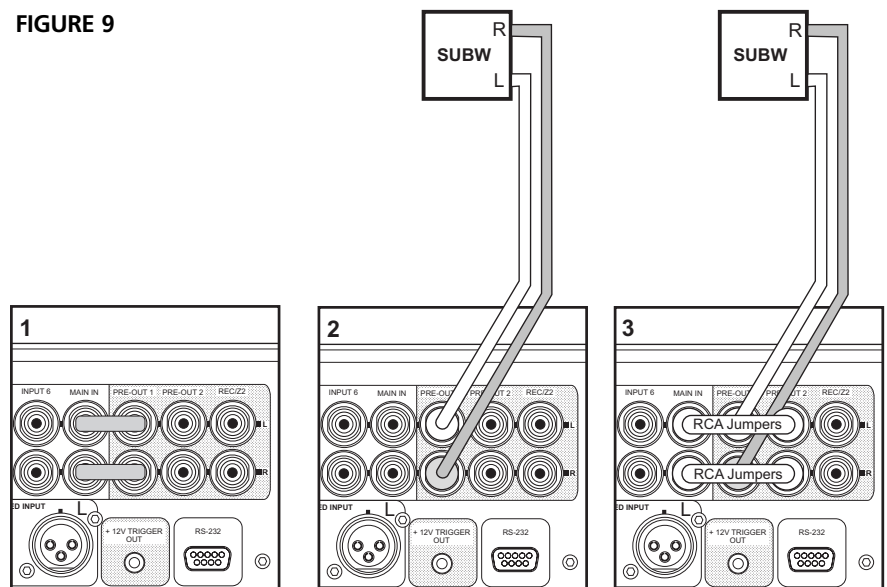

8. REC/Z2: This output is a steady state line-level output. Connect this output to recording equipment such as an audio tape deck or an A/D Converter recorder.

One may also connect this output to an auxiliary piece of audio equipment such as an integrated amplifier for multi-zone operation. In such a case, use this output in conjunction with the ZR3 remote control and **IR IN**. (refer to the **IR IN** section below).

9. SPEAKERS A: Connect speakers with impedance of 4 Ohms or greater. Connect the right speaker to the terminals marked 'R +' and 'R-' ensuring that the 'R+' is connected to the '+' terminal on your loudspeaker and the 'R-' is connected to the loudspeaker's '-' terminal. Connect the terminals marked 'L+' and 'L-' to the left speaker in the same way. When using both **SPEAKERS A** and **SPEAKERS B** connect speakers of impedance 8 Ohms or greater.

10. SPEAKERS B: Connect speakers with impedance of 4 Ohms or greater. Connect the right speaker to the terminals marked 'R +' and 'R-' ensuring that the 'R+' is connected to the '+' terminal on your loudspeaker and the 'R-' is connected to the loudspeaker's '-' terminal. Connect the terminals marked 'L+' and 'L-' to the left speaker in the same way. When using both **SPEAKERS A** and **SPEAKERS B** connect speakers of impedance 8 Ohms or greater.

NOTES: When connecting both **SPEAKERS A** and **B**, connect speakers with impedance no less than 8 Ohms.

Always use heavy duty (16 gauge/2 square mm or thicker) stranded wire to connect loudspeakers to your M3.

The high current binding post terminals can be used as a screw terminal for cables terminating in spade or pin connectors or for cables with bare wire ends.

SPADE CONNECTORS (Figure 3)

These should be slotted under the terminal's screw bushing, which is then fully tightened. Ensure the connector is tightly secured and there is no danger of bare metal from spade connectors touching the back panel or another connector as this may cause damage.

BARE WIRES AND PIN CONNECTORS (Figure 3)

Bare wires and pin connectors should be inserted into the hole in the shaft of the terminal. Unscrew the speaker terminal's plastic bushing until the hole in the screw shaft is revealed. Insert the pin or bare cable end into the hole and secure the cable by tightening down the terminal's bushing.

Avoid any danger of bare metal from the speaker cables touching the back panel or another connector. Ensure that there is only 1/2" (1cm) of bare cable or pin and no loose strands of speakers wire.

11. IR IN & IR OUT 2: Use these 3.5 mm mini-jack connectors to pass commands from other units with similar IR (infrared) connectors. Daisy-chain other hi-fi system's IR outputs to the M3's **IR IN** and then M3's **IR OUT 2** to other hi-fi systems' IR inputs so that control of a whole system via a single remote control facility is from one unit with a single IR connection.

NOTES: **IR OUTPUT 1** is hard wired to the M3's front panel IR sensor. Only Daisy-chain the **IR IN** with **IR OUT 2** when connecting the M3 as part of a series IR configuration.

Your custom installer or dealer can assist you in the proper setup and configuration of infrared multi-room hi-fi systems.

Setup

About the M3 Dual Mono Integrated Amplifier:

DB-9 Pin #	Function
2	Transmit Data
3	Receive Data
5	Signal Ground

DB-9 pin-out Assignment

12. IR OUT 1: The **IR OUT 1** is hard-wired to the M3's IR (infrared) sensor. Use this 3.5 mm mini-jack connector to pass commands from the M3's front panel IR sensor to other units with similar IR connectors. Daisy-chain the M3's **IR OUT 1** to other hi-fi system components' IR inputs to other IR outputs so that control of a whole system is via the M3's front panel IR sensor.

NOTE: Your custom installer or dealer can assist you in the proper setup and configuration of infrared multi-room hi-fi systems.

13. +12 V TRIGGER OUT: This +12V TRIGGER OUT will follow the powered state of the M3. Use this 3.5 mm mini-jack connector to pass +12 volts at a maximum current of 50 milliamps to auxiliary equipment such as a subwoofer, or other audio equipment. When the M3 is in standby, the output of this jack will be 0 Volts. When the M3 is in the on-state, the output will be +12 volts.

NOTES: The centre conductor (hot) of the 3.5 mm jack is the control signal. The outside conductor (shield) is the ground return-path.
Your custom installer or dealer can assist you in the proper setup and configuration of the +12V TRIGGER OUT interface.

14. RS-232: Using a Windows® operating system personal computer, one can remotely control the M3 with NAD's proprietary interface control software. This remote control facility employs a functional image of the M3's front panel as the GUI (graphical user interface). This connector is a standard DB-9 RS-232 configuration. Use an "off-the-shelf" DB-9 RS-232 serial cable to connect between your Windows® PC's DB-9 RS-232 connector and the M3's RS-232 connector.

NOTES: Please log onto www.nadelectronics.com for the latest M3 interface control software.

Use a standard DB-9 male to DB-9 female RS-232 serial cable between your Windows® PC and the M3. Do not use a null-modem type of RS-232 cable.

Some Windows® PC's may not have RS-232 serial connectors. In this event, use a standard "off-the-shelf" RS-232 to USB adaptor to connect to your Windows® PC. Follow the instructions that come with the RS-232 to USB adaptor for setting up the adaptor.

Your custom installer or dealer can assist you in the proper setup and configuration of the RS-232 interface.

Neither a DB-9 RS-232 serial cable nor a RS-232 to USB adaptor is supplied with the M3.

15. POWER Switch: The POWER switch supplies the master AC mains power for the M3. When this switch is in the ON position the M3 is in standby as shown by the amber Status Condition L.E.D. above the power switch on the front panel. If you intend not to use the amplifier for long periods of time, switch the POWER switch to the OFF position.

NOTE: When the POWER switch is in the OFF position, neither remote control ZR3, M3, nor the front panel Power switch will activate the M3.

16. IEC Power Cable Socket: Attach the M3's power cable to this IEC socket first, before connecting the power cable to the AC-mains outlet. Never disconnect the power cable from the IEC socket before disconnecting the power cable from the AC-mains outlet. Failure to follow this procedure may result in a possible electric shock hazard. Always make sure that the POWER switch is in the OFF position and disconnect the power cable from the AC-mains outlet, before disconnecting or changing input connections on the back panel.

NOTE: When connecting or disconnecting audio cables from the back panel of the M3, disconnect any auxiliary equipment from their AC-mains outlets as well. Failure to follow this procedure may result in possible damage to the either the M3 or other auxiliary equipment.

M3 REMOTE CONTROL HANDSET (FIGURE 3)

The Remote Control handset handles all the key functions of the M3 and has additional controls to remotely operate both NAD DVD and CD machines (see CD/DVD Switch below). It will operate up to a distance of 16ft (5m). Alkaline batteries are recommended for maximum operating life. Two AA (R6) batteries should be fitted in the battery compartment at the back of the Remote Control handset. When replacing batteries, check that they have been put in the right way round, as indicated on the base of the battery compartment.

Please refer to previous sections of the manual for a full description of individual functions. When a command from the remote control is received, the Status Condition L.E.D. will blink.

- 1. ON/OFF:** The **ON/OFF** buttons turn on and to standby the M3. These buttons will only function when the Status Condition LED is either blue representing the on-state, or amber representing the standby state.

To turn on the second zone output, first enable the **REC/Z2** button (3) as shown by the red LED beside the **REC/Z2** button, then press the **ON** button. To turn off the second zone output, enable the **REC/Z2** button, then press the **OFF** button. For further explanation of the second zone output controls, see **REC/Z2** button below.

- 2. Source Buttons:** There are 7 source buttons as well as a **REC/Z2** button. For direct input selection, press the appropriate input button.
- 3. REC/Z2:** Select this button to switch the remote control to a second zone remote control. The Source Buttons for the second zone will be active as shown by the red LED beside the **REC/Z2** button. There is a 3 second window for selecting a source before this button times out. Select the source within this duration.
- 4. SPEAKERS A & B:** Select to enable either speaker **A, B** or both **A & B**.
- 5. MODE:** Press the **MODE** button to toggle through the four listening modes. A press longer than one second will advance the mode selection to the next state as follows; STEREO, MONO, LEFT, RIGHT, and then return to the STEREO listening mode. Release the **MODE** button to stop the sequence.
- 6. MUTE:** Press the **MUTE** Button to temporarily switch off the sound to the speakers. The word **MUTE** will continuously display in the VFD. Press **MUTE** again or the volume control to restore sound. The mute function does not affect recordings made using the **REC/Z2** output but will affect the signal going to both Preamp outputs.
- 7. VOL (Volume):** Press the **VOL ▲** or **▼** buttons to respectively increase or decrease the loudness level. Release the button when the desired level is reached. The VFD on the front panel will indicate the level set. The Master Volume buttons do not affect recordings made using the **REC/Z2** outputs but only affect the signals going to the Preamp outputs.
- 8. BALANCE:** Press the balance button once and then within 5 seconds, press the **VOL ▲** or **▼** buttons respectively to adjust the either the LEFT or RIGHT balance level. After about 5 seconds, the balance menu will switch off saving the balance settings in memory.
- 9. TONE:** Press the **TONE** button to activate or deactivate the tone controls. Release the **TONE** button to stop the sequence. To bypass bass, treble, and spectral tilt controls completely, select TONE DEFEAT (direct bypass of all analogue filters).

Selecting TONE ACTIVE allows one to adjust the bass, treble, and spectral tilt settings of the M3 by pressing the **VOL ▲** or **▼** buttons respectively. Bass and treble levels are adjustable between +/- 5dB. The spectral tilt adjustment allows for simultaneous +/-3dB bass and treble offsets. When adjusting bass and treble levels, the spectral tilt value will remain 0dB. When adjusting the spectral tilt, the bass and treble values will follow the spectral tilt adjustment simultaneously.

Operation

About the M3 Dual Mono Integrated Amplifier:

10. BI AMP: Press the **BI AMP** button to toggle through the filter sequence. A press longer than one second will advance the crossover frequency selection as follows; BIAMP CROSSOVER FULL RANGE, HIGH PASS 40 Hz, HIGH PASS 60 Hz, HIGH PASS 80 Hz, HIGH PASS 100 Hz, and then return to FULL RANGE. Release the **BI AMP** button to stop the sequence.

11. DVD/CD Switch: Inside the battery compartment is a selection switch for the M3 remote control (see figure 4). Position **1**-setting controls the NAD DVD-players while position **2**-setting controls NAD CD-players. Using a paper clip, select either position **1** or **2** taking care not to damage the switch with excessive force.

12. Navigation/Transport Buttons (DVD): With the DVD/CD Switch set to the position **1**-setting the navigation buttons **▲/▼/◀/▶** and **ENTER** will allow navigation of DVD on screen menus. The **TITLE**, **MENU**, **DISP** (display), and **RTN** (return) buttons function as they do on an NAD DVD's remote control. The transport buttons now control NAD DVD-players.

12. Navigation/Transport Buttons (CD): With the DVD/CD Switch set to the position **2**-setting the navigation buttons will be inoperative. The **TITLE** button will become a Repeat function button, the **MENU** button will become a Random function button, and the **DISP** button will become a Time function button. The transport buttons now control NAD CD-players.

ZR3 REMOTE CONTROL HANDSET (FIGURE 5)

1. ON/OFF: The M3 must be in its on-state in order to use the **ZR3** remote control. Press **ON** to turn on the **REC/Z2** output; press **OFF** to turn off the **REC/Z2** output. Once the **REC/Z2** output is on, one can select the source inputs.

NOTE: the **REC/Z2** output is a fixed line level output. The volume control of the M3 does not control the level of this output.

2. Source Buttons: There are 8 source buttons for direct input selection, press the appropriate input button once the **REC/Z2** is in the on-state.

3. SOURCE: Press the **◀** or **▶** buttons to select the input as the recording source. A press longer than one second will advance the source selection to the next input as follows; OFF RECORD, DISC RECORD, CD RECORD, TUNER RECORD, INPUT 4 RECORD, INPUT 5 RECORD, INPUT 6 RECORD, BALANCED RECORD, LOCAL RECORD, and then return to OFF RECORD. Release the **◀** or **▶** buttons to stop the sequence.

4. LOCAL: Press this button to directly select the source the main zone is set to. The **REC/Z2** output will automatically follow the input selection.

Problem	Cause	Solution
NO SOUND	<ul style="list-style-type: none"> Power AC lead unplugged or power not switched on Incorrect Mode selected Mute on Rear Pre-out/Main-in amp links not fitted No speakers selected 	<ul style="list-style-type: none"> Check if AC lead is plugged in and power switched on Select Stereo Mode Switch off Mute Fit links Select the appropriate speakers (A / B)
NO SOUND ONE CHANNEL	<ul style="list-style-type: none"> Balance control not centred Speaker not properly connected or damaged. Input lead disconnected or damaged Mode selected to Left or Right or Mono channel 	<ul style="list-style-type: none"> Centre Balance control Check connections and speakers Check leads and connections Select Stereo Mode
WEAK BASS / DIFFUSE OR NO STEREO IMAGE	<ul style="list-style-type: none"> Speakers wired out of phase Biamp mode selected with high pass filter Mode set to Left or Right or Mono channel 	<ul style="list-style-type: none"> Check connections to all speakers in the system Set biamp to FULL RANGE Select Stereo Mode
REMOTE CONTROL HANDSET NOT WORKING	<ul style="list-style-type: none"> Batteries flat, or incorrectly inserted IR transmitter or receiver windows obstructed IR receiver in direct sun or very bright ambient light ZR3 remote used with M3 in Standby. 	<ul style="list-style-type: none"> Check or replace batteries Remove obstruction Place unit away from direct sun, reduce amount of ambient light Turn on M3. M3 must be in ON to use ZR3.
POWER/PROTECTION LED STAYS RED UPON TURNING POWER ON	<ul style="list-style-type: none"> Loudspeakers cabling has a short-circuit 	<ul style="list-style-type: none"> Turn amplifier off and check loudspeaker cable connections for both speakers at amplifier's back panel and loudspeakers. Turn amplifier on.
POWER/PROTECTION INDICATOR TURNS RED DURING OPERATION	<ul style="list-style-type: none"> Amplifier has over-heated. Overall impedance of loudspeakers too low 	<ul style="list-style-type: none"> Turn amplifier off. Make sure ventilation slots on top and bottom of amplifier aren't blocked. After amplifier has cooled down, turn back on. Ensure the overall loudspeaker impedance isn't below 4 ohms. Check loudspeaker cables for short circuits

PRE-AMP SECTION

Line level inputs	
Input impedance (R+C)	150k Ω /500pF
Balanced Input impedance (R+C)	120k Ω /100pF
Input sensitivity, rated power	446mV
Frequency response (5Hz - 70kHz) ¹	<+/-0.3dB

LINE LEVEL OUTPUTS

Output impedance	100 Ω
Tape	Source Z + 1k Ω
Signal/noise ratio	>110dB (AWTD)

TONE CONTROLS

Bass	\pm 5dB
Treble	\pm 5dB
Spectral Tilt	\pm 3dB

+12VOLT TRIGGER OUT

Output Voltage	+12V +/- 20%
Minimum Output Current	>40mA
Maximum Short Circuit Current	<60mA

POWER AMP SECTION

Continuous output power into 4/8 Ω ²	180W (23dBW)
Rated Distortion (THD 20Hz - 20kHz)	0.004%
Clipping power ³	220W (23.4dBW)
IHF dynamic headroom at 4 Ω	+4.2dB
IHF dynamic power at 8 Ω	\geq 280W (24.5dBW)
IHF dynamic power at 4 Ω	\geq 480W (26.8dBW)
IHF dynamic power at 2 Ω	\geq 785W (29.0dBW)
Damping factor (ref. 8 Ω , 50Hz)	>150
Input impedance	20k Ω / 680pF
Input Sensitivity (for rated power into 8 Ω)	1.38V
Voltage gain	29dB
Frequency response; 20Hz-20kHz	+/-0.03dB
Frequency response; at > 80kHz	-3dB
Signal/noise ratio; ref 1W	>107dB (AWTD)
Signal/noise ratio; ref rated power	>130dB

PHYSICAL SPECIFICATIONS

Dimensions (W x H x D):	
Net:	17.2 x 5.3 x 15.2" (435 x 135 x 386mm)
Gross: ⁴	17.2 x 5.8 x 17.2" (435 x 147 x 435mm)
Net Weight	51.8 lbs (23.5 kg)
Shipping Weight	68.3 lbs (31.0kg)

¹ From CD input to speakers output, volume setting for 500mV in, 8 Ω 1W out

² Minimum power per channel, 20Hz - 20kHz, both channels driven with no more than rated distortion.

³ Maximum continuous power per channel 4 Ω and 8 Ω

⁴ Gross dimensions include feet, volume knob and extended speaker terminals.

INPUT	ORIGINAL LABEL	NEW LABEL
DISC	DISC	-----
CD	CD	-----
TUNER	TUNER	-----
INPUT 4	INPUT 4	-----
INPUT 5	INPUT 5	-----
INPUT 6	INPUT 6	-----
BALANCED	BALANCED	-----



www.NADelectronics.com

**©2006 NAD ELECTRONICS INTERNATIONAL
A DIVISION OF LENBROOK INDUSTRIES LIMITED**

All rights reserved. No part of this publication may be reproduced, stored or transmitted in any form without the written permission of NAD Electronics International

M3 Manual 01/06 Printed in China